

FOUR SIGHT

Advanced Video Quad

Simultaneous monitoring made easy

FourSight is an advanced video quad display system that allows up to four cameras to be viewed on one screen making it ideal for surveillance monitoring applications.

- **One monitor can view four cameras simultaneously**
- **Choice of 16 user-configurable display modes**
- **Full control of scale, crop, position and overlay for each channel**
- **High quality, real-time update rate per channel**
- **Automatic configuration for PAL or NTSC video inputs**
- **RS232 control of all functions with optional PC configuration utility**
- **Small rugged unit makes it ideal for mobile and covert installations**

Unlike less sophisticated quads, FourSight's advanced digital video processing provides full control of each picture's size and position together with picture cropping and overlay. For ease of use the system includes 16 pre-set display modes and can be reconfigured via its RS232 port and PC configuration utility. FourSight provides excellent picture quality coupled with real-time update rate per channel.

FourSight will operate with almost any video source, automatically configuring itself for PAL or NTSC operation. FourSight consists of a small DC powered unit that is rugged and weatherproof making it ideal for covert and mobile installations.

For OEM applications, the system can be supplied as a unit or PCB, together with full support for interfacing to the product's serial control protocol.

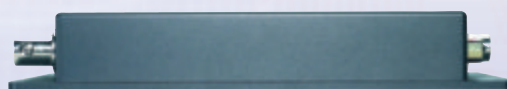

end and side views



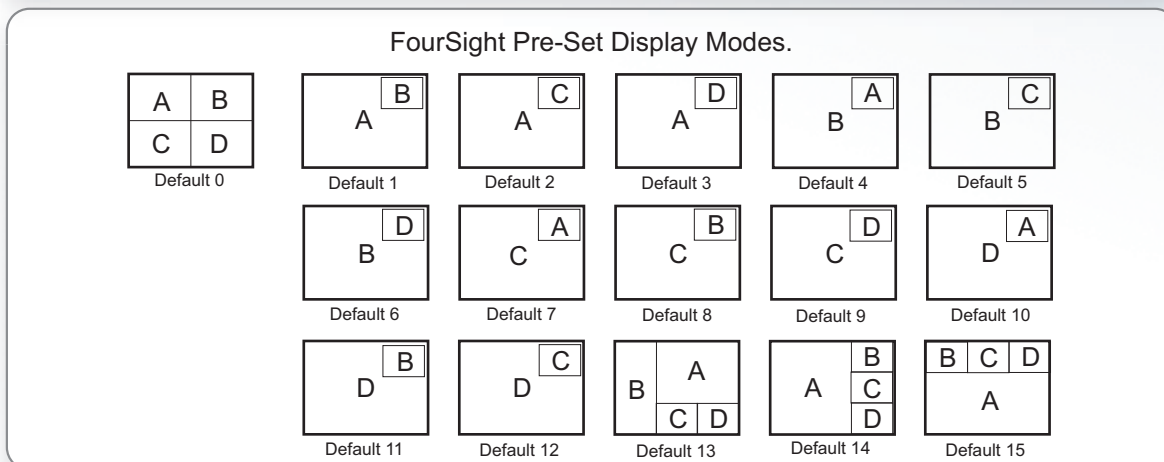
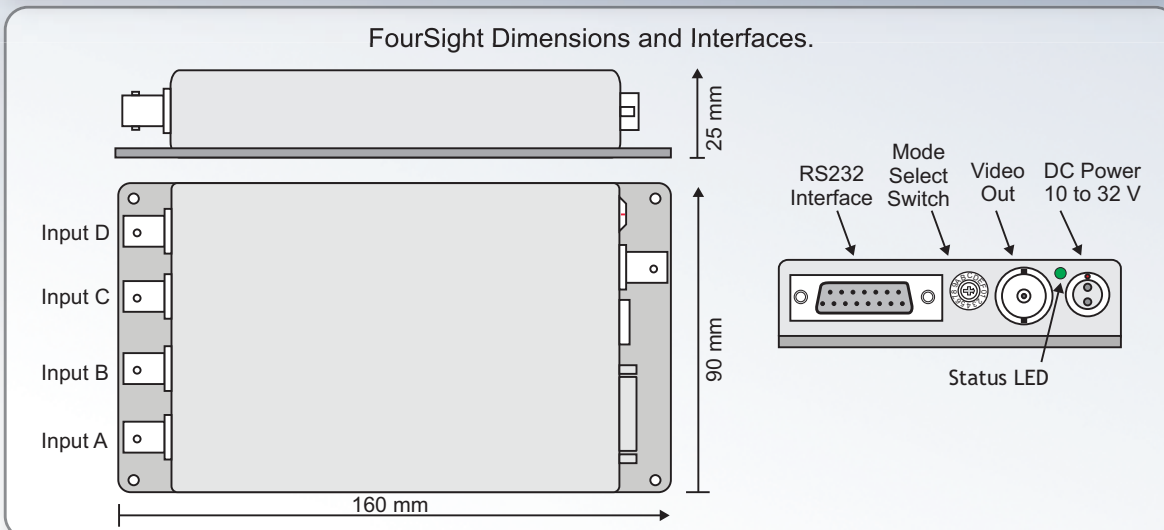
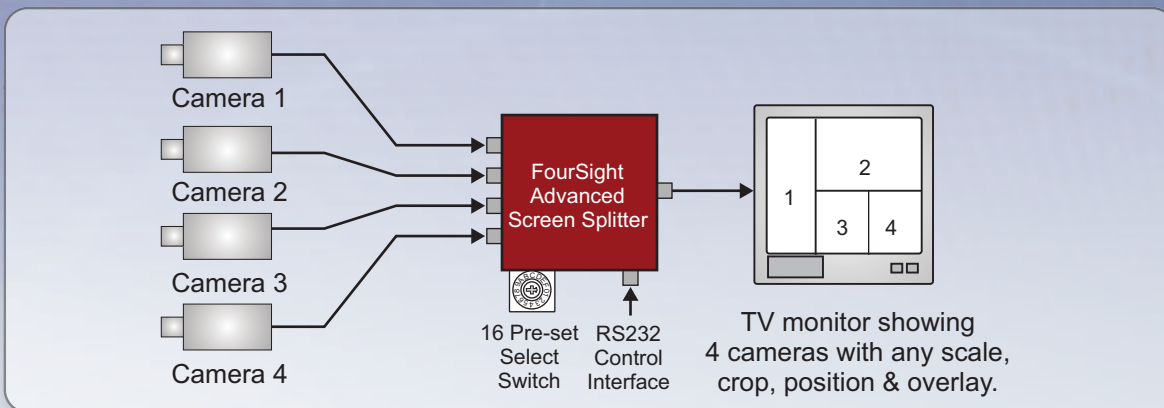

Outline Specification

General:	Video:
Operating temperature range	0 to +45°C
Mechanical size (housed)	160 x 90 x 25 mm
Finish	Hard anodised aluminum
Weight (housed)	440 g
DC power connector	2 pin Lemo
Operating voltage range	10 to 32 V DC
Power consumption	< 5 Watts
Current consumption at 12 V	410 mA (approx)
Standard accessories	User guide, DC lead, PC software CD, programming cable, carry case
Control port	RS232 (protocol available on request)
	Video standards supported
	PAL or NTSC (auto config)
	Video connectors
	BNC
	Video Input / output levels
	1 Vpp into 75R
	Digital sampling
	PAL: 576 lines by 720 pixels, NTSC: 488 lines by 720 pixels
	Lock-in time
	< 1 second
	Input camera gen-lock
	Not required
	Number of input channels
	4
	Preset-display modes
	16 via switch + 16 via RS232
	Update rate per image
	Real-time
	Scale
	1 to 1/64
	Crop
	to 1 pixel resolution
	Position
	to 1 pixel resolution

Please note, Ovation Systems reserves the right to change specifications without notice. E&OE.

