

- Large housing
- AISI 304 stainless steel construction
- Wide range of accessories available
- Optional wiper and washer
- Weatherproof standard IP54

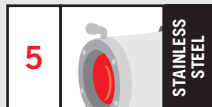

The NXJ housing, entirely made of AISI 304 stainless steel, has been designed to accommodate large cameras and zoom lenses.

On request, an AISI 316 stainless steel version, designed to operate in highly corrosive environments, is also available. The NXJ housing has a frontal section of 180x169 mm and is 500 mm in length. It consists of a base with an internal slide and a body which closes by means of three hinges.

The large window on the front makes it suitable for various zoom lenses. It is equipped with 2 PG9 cable glands for the connections and is pre-arranged for the bracket mounting and the wiper installation.

A wide range of accessories is available, including heater, blower kit, camera power supply, stainless steel special brackets and possibility to mount the wiper and washer.

MODELS			
	Sunshield	Heater 115/230VAC	Heater 12VDC/24VAC
NXJ1	•	•	
NXJ2	•		•

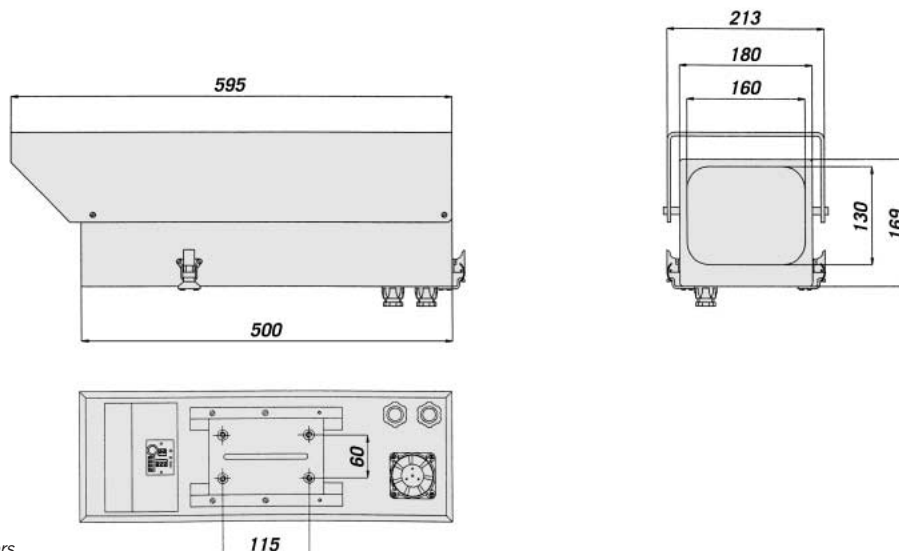

The values are in millimeters.

TECHNICAL DATA

GENERAL

- Made of AISI 304 stainless steel
- Epoxypolyester powder painted RAL9002 colour
- Opening/closure by means of three hinges

MECHANICAL

- 2xPG16 cable glands
- Dimensions WxHxL: 180x170x500 mm (7x6.6x19.6 in)
- Internal usable dimensions WxHxL: 177x126,2x490 mm (6.9x4.9x19.2 in)
- Glass window WxH: 160x13 mm (6.3x0.5 in)

Wiper VIPNX:

- Wiperblade and enclosure made of AISI 316 stainless steel
- Dimensions (ØxL): 100x169 mm (3.9x6.6 in), not comprehensive of blade
- Weight: 1,5 kg (3.3 lb)
- Connector 3+1 pins

Washer pump:

VIP5WAS:

- Dimensions WxHxL: 217x272x254 mm (8.5x10.7x10 in)
- Reservoir capacity: 5 l (1.3 gal), Delivery head: max 5 m (16 ft)

VIP25WAS:

- Dimensions WxHxL: 301x458x345 mm (11.8x18x13.5 in)
- Reservoir capacity: 25 l (6.6 gal), Delivery head: max 5 m (16 ft)

VIP25WASA01:

- Dimensions WxHxL: 710x300x270 mm (28x12x11 in)
- Reservoir capacity: 25 l (6.6 gal), Delivery head: max 30 m (98.5 ft)

ELECTRICAL

Heater, Ton 15°C+/-3°C (59°F) Toff 22°C +/-3°C (71°F):

IN 12VDC/24VAC, consumption 20W / 115/230VAC, consumption 40W

Blower kit with air filter and thermostat, Ton 35°C +/-3°C(95°F) Toff 20°C +/-3°C(68°F):

ONXJVF1 IN 12VDC, consumption 4W (max)

ONXJVF2 IN 24VAC, consumption 4W (max)

ONXJVF3 IN 230VAC, consumption 4W (max)

Camera power supply:

ONXJPS1 IN 230VAC, 50Hz - OUT 12VDC, 400mA max

ONXJPS2 IN 230VAC, 50Hz - OUT 24VAC, 400mA max

Wiper:

VIPNXJ1 IN 230VAC, 50/60Hz, consumption 7W

VIPNXJ2 IN 24VAC, 50/60Hz, consumption 7W

Washer Pump:

VIP5WAS01 IN 230VAC, consumption 12W

VIP5WAS02 IN 24VAC, consumption 12W

VIP25WAS01 IN 230VAC, consumption 12W

VIP25WAS02 IN 24VAC, consumption 12W

VIP25WASA01 IN 230VAC, consumption 600W

ACCESSORIES

ONXJVF1 Blower with thermostat and air filter IN 12VDC

ONXJVF2 Blower with thermostat and air filter IN 24VAC

ONXJVF3 Blower with thermostat and air filter IN 230VAC

ONXJPS1 Camera power supply IN 230VAC - OUT 12VDC

ONXJPS2 Camera power supply IN 230VAC - OUT 24VAC

VIPNXJ1 New AISI 316 Stainless Steel wiper kit IN 230VAC, 50/60Hz

VIPNXJ2 New AISI 316 Stainless Steel wiper kit IN 24VAC, 50/60Hz

VIP5WAS01 IN 230VAC washer pump with tank 5 l (1.3 gal)

VIP5WAS02 IN 24VAC washer pump with tank 5 l (1.3 gal)

VIP25WAS01 IN 230VAC washer pump with tank 25 l (6.6 gal)

VIP25WAS02 IN 24VAC washer pump with tank 25 l (6.6 gal)

VIP25WASA01 IN 230VAC washer pump with tank 25 l (6.6 gal)

OMARPTH Adapter kit for installation on PTH900 P&T's series

RELATED PRODUCTS

Brackets:

NXWBS Heavy duty housing stainless steel wall mount

ENVIRONMENT

- Indoor/outdoor
- Operating temperature: -20°C +50°C (-4 +122°F)
- Salt-air fog resistance

COMPLIANCE TO

- CE according to EN 61000-6-3, EN 60065, EN 50130-4
- IP54



Unit Weight (kg / lb):
NXJ: 9,6 / 21

Package Weight (kg / lb):
NXJ: 10,2 / 22.4

Package Dimensions (cm / in):
NXJ: 24,5x24,5x62 / 9.6x9.6x24.4

Master Carton (units):
NXJ: