

- Indoor installation
- Sheet steel construction
- Vandal resistant polycarbonate glass
- Epoxypolyester painted
- Key lock



4



AVTPSKB housing have been designed for surveillance applications in places highly exposed to vandalism (underground parking lots, subway stations, prisons, police stations, corridors, supermarkets, etc).

AVTPSKB is made of sheet steel (2,5 mm thick) and painted with epoxypolyester powder.

The housing is equipped with an internal bracket for the camera attachment and adjustment.

The compass opening allows ease installation and maintenance. The AVTPSKB is individual or common key locked according to the models.

A vandal resistant polycarbonate glass is fixed on the front by means of an iron frame.

The cable outlet is made possible from the fixing base and from the 3 M20 cable glands on the back side. AVTPSKB can eventually be equipped with heater, camera power supply and alarm tamper switch

## MODELLI

<b>AVTPSK0A000B</b>	Vandal resistant wedge housing with individual lock and key
<b>AVTPSK0A101B</b>	Vandal resistant wedge housing with common lock and key



## AVTPSKB

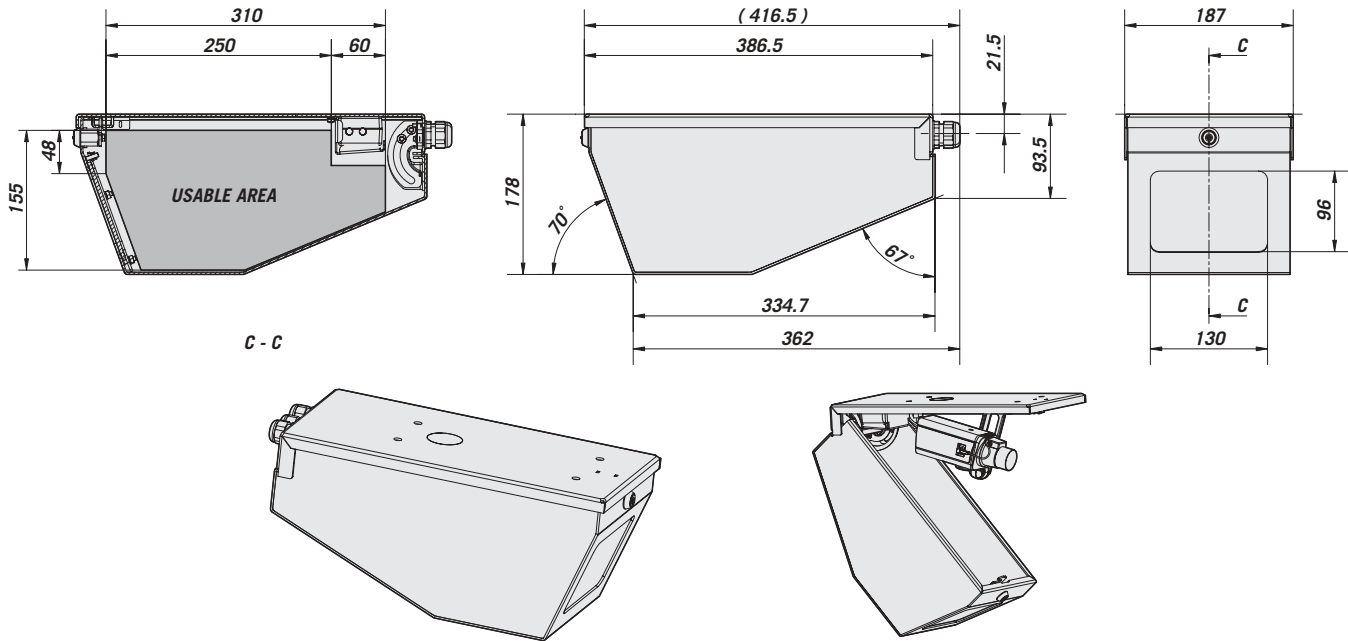

The values are in millimeters.

## TECHNICAL DATA

## GENERAL

- Build in sheet steel 3 mm thick (0.12 in)
- Epoxy polyester powder painted RAL9002
- Glass frame made in iron
- Vandal resistant polycarbonate glass 4 mm (0.15 in) thick
- Compass opening

## MECHANICAL

- External dimensions (WxHxL): 386,5x178x187 mm (15.2x7x7.4 in)
- Individual key locked (AVTPSK0A000B)
- Common key locked (AVTPSK0A101B)
- Cable outlet through fixing side or 3 M20 cable glands
- Window dimensions: 130x96 mm (5.1x3.8 in)

## ELECTRICAL

Heater, ton 15°C+/-3°C (59°F) toff 22°C +/-3°C (71°F):

- OAVTPSH1B** IN 12V DC/24V AC, consumption 20W  
**OAVTPSH2B** IN 115/230V AC, consumption 40W

## Camera power supply:

- OAVTPSPS1B** IN 100-240V AC, 50/60Hz - OUT 12V DC, 1A max  
**OAVTPSPS2B** IN 230V AC, 50Hz - OUT 24V AC, 400mA max

## ACCESSORIES

- OTPSTA** Micro tamper switch  
**OAVTPSH1B** Heater IN 115/230V AC  
**OAVTPSH2B** Heater IN 12V DC/24V AC  
**OAVTPSPS1B** Wide range power supply IN 100-240V AC - OUT 12V DC  
**OAVTPSPS2B** Power supply IN 230V AC - OUT 24V AC

## ENVIRONMENTS

- Indoor

## COMPLIANCE TO

- CE according to EN 61000-6-3, EN 60065, EN 50130-4
- IK10

## SPARE PARTS LIST

- OSER1B** Individual spare key/lock  
**OSER2B** Common spare key/lock  
**OVET2TPSKB** Spare polycarbonate glass



Unit Weight (kg / lb):  
AVTPSKB: 6,3 / 13,8

Package Weight (kg / lb):  
AVTPSKB: 6,7 / 14,7

Package Dimensions (cm / in):  
AVTPSKB: 22x20x44 / 8.7x7.9x17.3

Master Carton (units):  
AVTPSKB: 5