

SSP-T200 series

Light curtain sensors for picking

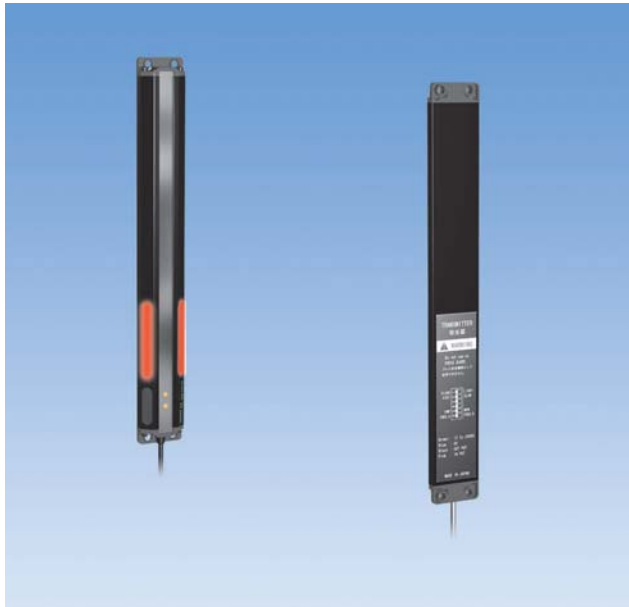

- Picking sensor for checking and instruction of removing parts from bin
- Thinness of 13 mm achieved with rigid metal case
- Large work operation indicator (job light)
- Faulty work operation indicator (fault light) is provided
- 4 types are available for different sizes of parts bins
- Requiring no synchronization line
Asynchronous method employed, eliminating need for synchronization line

Light Curtain Sensors

Type

Detection method	Detecting distance	Detecting width	Set model No.	No. of light axes	Light axis interval	Detecting object	Connection
 Through-beam type	 2m max.	100mm	SSP-T205	5	25mm	Opaque object of ϕ 35mm min.	Permanently attached cord
		225mm	SSP-T210	10			
		300mm	SSP-T213	13			
		375mm	SSP-T216	16			
		100mm	SSP-T205-J	5			Permanently attached cord with connector
		225mm	SSP-T210-J	10			
		300mm	SSP-T213-J	13			
		375mm	SSP-T216-J	16			

Mounting brackets are separately available.

Special mounting brackets (optional)

Model	Model	Remarks
SSP-B1	Flat plate type	Two brackets in one set
SSP-B2	L-shaped plate type	(with M4 x 12 sems screws with washers and nuts)

- Two sets are required for transmitter and receiver.

Cord with connector (optional)

Model	Shape, etc.
FAC-D4R2	M12 straight 4-core cord / 2 m (common to transmitter and receiver)
FAC-D4R5	M12 straight 4-core cord / 5 m (common to transmitter and receiver)

Rating/Performance/Specification

Model	Permanently attached cord type	SSP-T205	SSP-T210	SSP-T213	SSP-T216	
	In-line connector type	SSP-T205-J	SSP-T210-J	SSP-T213-J	SSP-T216-J	
Rating/performance	Detection method		Through-beam type			
	Detecting distance		2m			
	Detection object		Opaque object of ϕ 35mm min.			
	No. of light axes		5	10	13	16
	Detecting width		100mm	225mm	300mm	375mm
	Light axis interval		25mm			
	Power supply		12-24V DC \pm 10% / Ripple 10% max.			
	Current consumption		130mA max.	140mA max.	150mA max.	155mA max.
	Output mode	Control output		Selectable between NPN and PNP with switch		
		Rating	NPN output	Sink current 50mA (30VDC) max. / Residual voltage: 2V max.		
			PNP output	Source current: 50mA (30VDC) max. / Residual voltage: 2V max.		
	Operation mode		Light-ON/Dark-On selectable (with switch)			
	Frequency switching feature		Provided (for up to 2 units)			
	Response time	Normal	Light reception: 35 ms max.	Light reception: 68 ms max.	Light reception: 70 ms max.	Light reception: 94 ms max.
Light blocking: 25 ms max.			Light blocking: 42 ms max.	Light blocking: 42 ms max.	Light blocking: 58 ms max.	
With frequency switching feature enabled		Light reception: 45 ms max.	Light reception: 74 ms max.	Light reception: 88 ms max.	Light reception: 116 ms max.	
		Light blocking: 28 ms max.	Light blocking: 52 ms max.	Light blocking: 54 ms max.	Light blocking: 72 ms max.	
Job light input		Contact or non-contact input				
Light source (wavelength)		Infrared LED (wavelength;880nm)				
Indicator		Transmitter: Power indicator (green LED) / Job light (green LED) Receiver :Light reception indicator (green / orange LED) / Light blocking indicator (orange LED) Job light (green LED) / Fault light (red LED)				
Job light Fault light		Continuous/flashing illumination selectable with switch Flashing speed: FAST/SLOW selectable with switch				
Short circuit protection		Provided				
Automatic sensitivity compensation		Provided				
Material		Case body: Aluminum / Caps at ends (mounting legs): glass fiber filled PBT Lens: polycarbonate / Switch cover: polyester elastomer				
Connection	Permanently attached cord	(Outer dimension: dia.4.1) Cord length: 2m Transmitter: with three 0.2mm ² cores, gray (transmitter) /with four 0.2mm ² cores, black (receiver) covering				
	Permanently attached cord with connector	With M12 connector, 2m long Cord color: transmitter: Gray / Receiver: Black				
Mass	Permanently attached cord	Transmitter: about 105g Receiver: about 110g	Transmitter: about 160g Receiver: about 170g	Transmitter: about 195g Receiver: about 205g	Transmitter: about 225g Receiver: about 240g	
	Permanently attached cord with connector	Transmitter: about 115g Receiver: about 120g	Transmitter: about 170g Receiver: about 180g	Transmitter: about 205g Receiver: about 215g	Transmitter: about 235g Receiver: about 250g	
Accessory		Screwdriver for switch operation (Note) Mounting brackets are separately available.				
Specification						

Environmental Specification

Environmental specification	Ambient light	10,000lx max.
	Ambient temperature	-10 - +55°C (non-freezing)
	Ambient humidity	35-85%RH (non-condensing)
	Vibration	10 - 55Hz / 1.5mm amplitude / 2 hours each in 3 directions
	Shock	500m/s ² / 2 times each in 3 directions
	Protective structure	IP62
	Dielectric withstanding	1,000VAC 50/60Hz for 1 minute
	Insulation resistance	500VDC, 20M Ω or higher.

SSP-T200

Input/Output Circuit and Connection

Use the mode switch for job light and NPN/PNP receiver output.

For NPN output

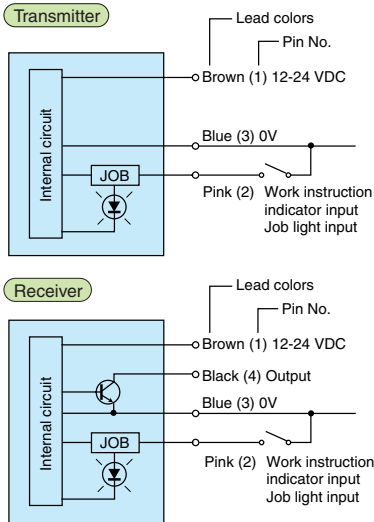

For PNP output

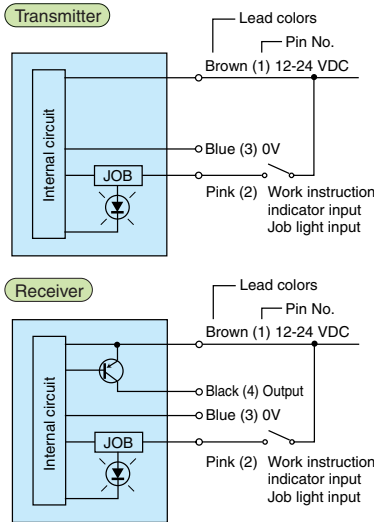

Connector pin arrangement for permanently attached cord with connector (-J type)

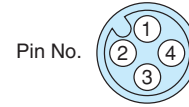

• Connection

For NPN

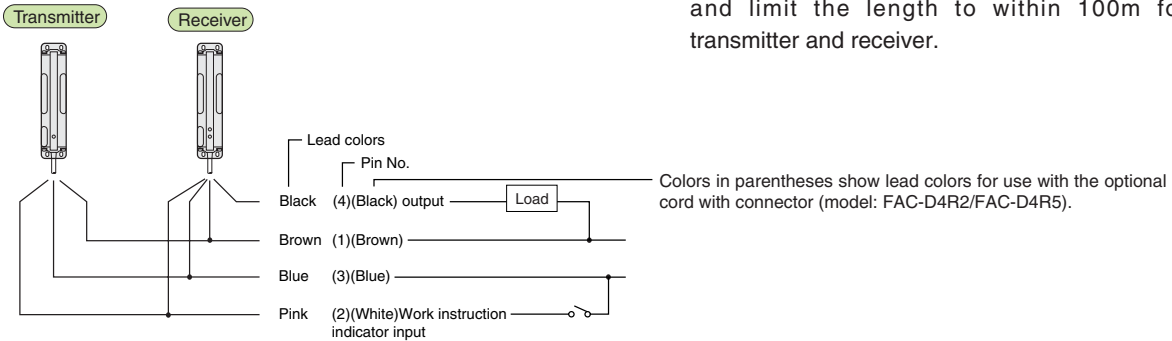

• Cord extension

To extend the cord, use wires of at least 0.5mm² and limit the length to within 100m for transmitter and receiver.

Characteristics (Typical Example)

• Parallel displacement characteristics

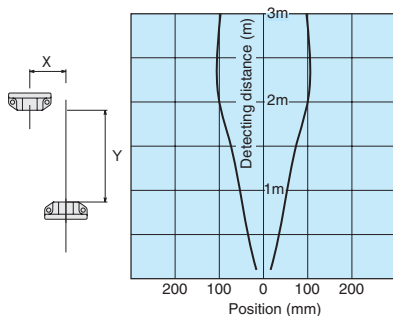

• Parallel displacement characteristics Longitudinal

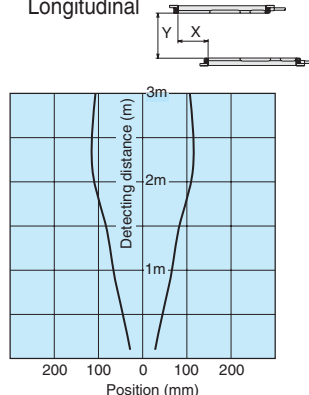

• Operating angle characteristics

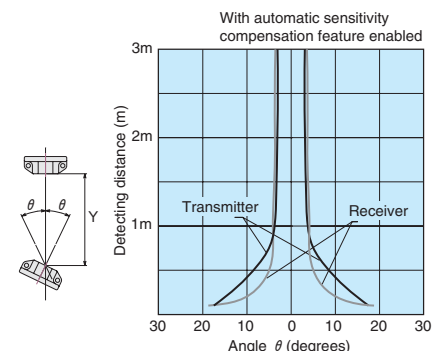

Mode Switching

Transmitter

1. Job light illumination pattern
2. Job light flashing speed switch
3. NC
4. . NC
5. NPN/PNP switch
6. Frequency switching feature

Flash	1	Light
Fast	2	Slow
	3	
	4	
PNP	5	NPN
A	6	B

Receiver

1. Job light illumination pattern
2. Job light flashing speed switch
3. Operation mode switch
4. Fault light setting
5. NPN/PNP switch
6. Frequency switching feature

Flash	1	Light
Fast	2	Slow
Dark on	3	Light on
Fault on	4	Fault off
PNP	5	NPN
A	6	B

Explanation of modes

- Job light illumination pattern
Selects between continuous and flashing illumination for the job light and receiver fault light.
Light: continuous illumination / Flash: flashing illumination
- Job light flashing speed switch
Specifies the flashing speed for the job light and receiver fault light.
- Operation mode switch
Selects between receiver output modes.
- Fault light setting
Specifies the operation of the fault light.
- NPN/PNP switch
Specifies the job light input and receiver output mode.
- Frequency switching feature
Allows setting of different frequencies for A and B with the frequency switch.
Be sure to select the same frequency (A or B) for the transmitter and receiver facing each other.

Indicators

Transmitter



Power indicator: green LED

Receiver

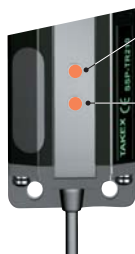

Light blocking indicator: orange LED
Illuminated when light beam is blocked with object.

Light reception indicator: green/orange LED
Green: illuminated to indicate stable light reception.
Orange: illuminated to indicate unstable light reception or light blocking.

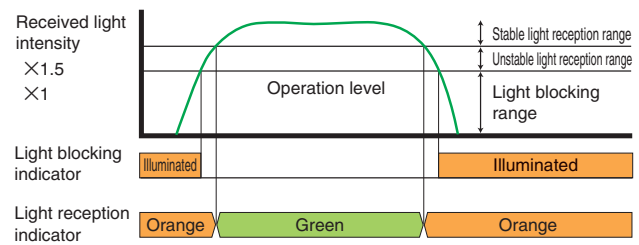

Job light and fault light

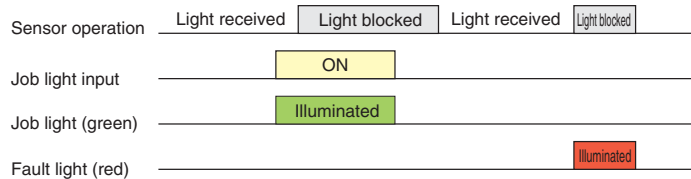

Automatic Sensitivity Compensation Feature

After the light axis alignment is completed, turn the power off once and back on. The automatic sensitivity compensation feature is enabled and the sensitivity is set at the optimum for the sensor.

If the lens is soiled with dirt or dust, the sensitivity is automatically compensated to achieve the optimum sensitivity after the soil is removed.

SSP-T200

Notes on Installation

- Install the transmitter and receiver directly face-to-face and firmly secure them to prevent light axis misalignment due to vibration, etc.
- When installing the sensor, make sure that the ends of the transmitter and receiver with the cord are oriented either upward or downward. The sensor does not function if the transmitter and receiver are not oriented the same way.
- Use M4 screws for mounting and limit the tightening torque to within $0.8\text{N} \cdot \text{m}$. (Prepare screws, etc. separately.)
- Any reflecting object (wall, floor, machine, etc.) within the effective range between the transmitter and receiver may allow the light of the sensor to go around the detection object, which is supposed to block the light, and reach the receiver. Choose the installation location carefully.

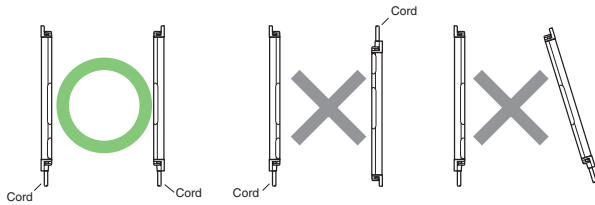

For Correct Use



- Be sure to follow the instructions in the operation manual provided for correct use of the product.
- This sensor cannot be used as a press safety device or other safety device for protection of human body that requires conformity to domestic or overseas standards or certification concerning protection of human body. Use for such purposes may lead to death or serious injury in the unlikely event of failure.
- This sensor is intended for detection of ingress of human body or object passing through an arbitrary point not involving protection of human body or safety.
- When using this sensor for safety purposes, ensure safe operation of the system as a whole including detection and control.

SSP-T200

Dimensions (in mm)

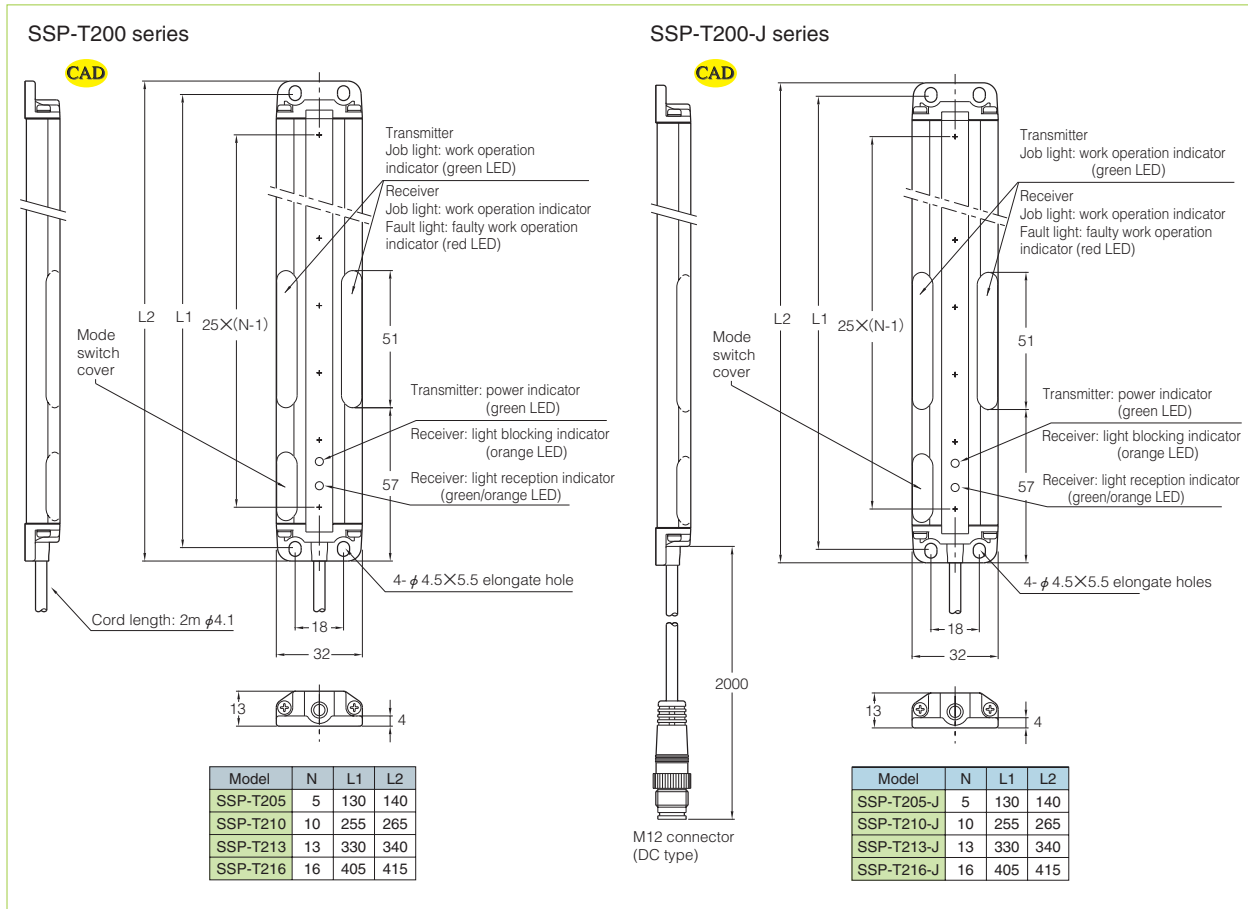

Optional parts

Mounting brackets

- Two types of mounting brackets are available.
- Two brackets are required to mount either of the transmitter and receiver. Mounting brackets are available in sets of two.
- Four sems screws with M4 x 12 washers and nuts are provided.

Model:SSP-B1
Flat plate type

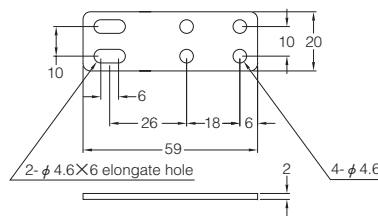

Model:SSP-B2
L-shaped plate type

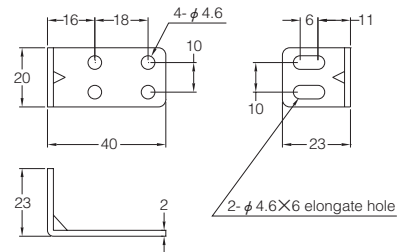

Cord with connector

Model:FAC-D4R2 (L:2m)
FAC-D4R5 (L:5m)

CAD

