

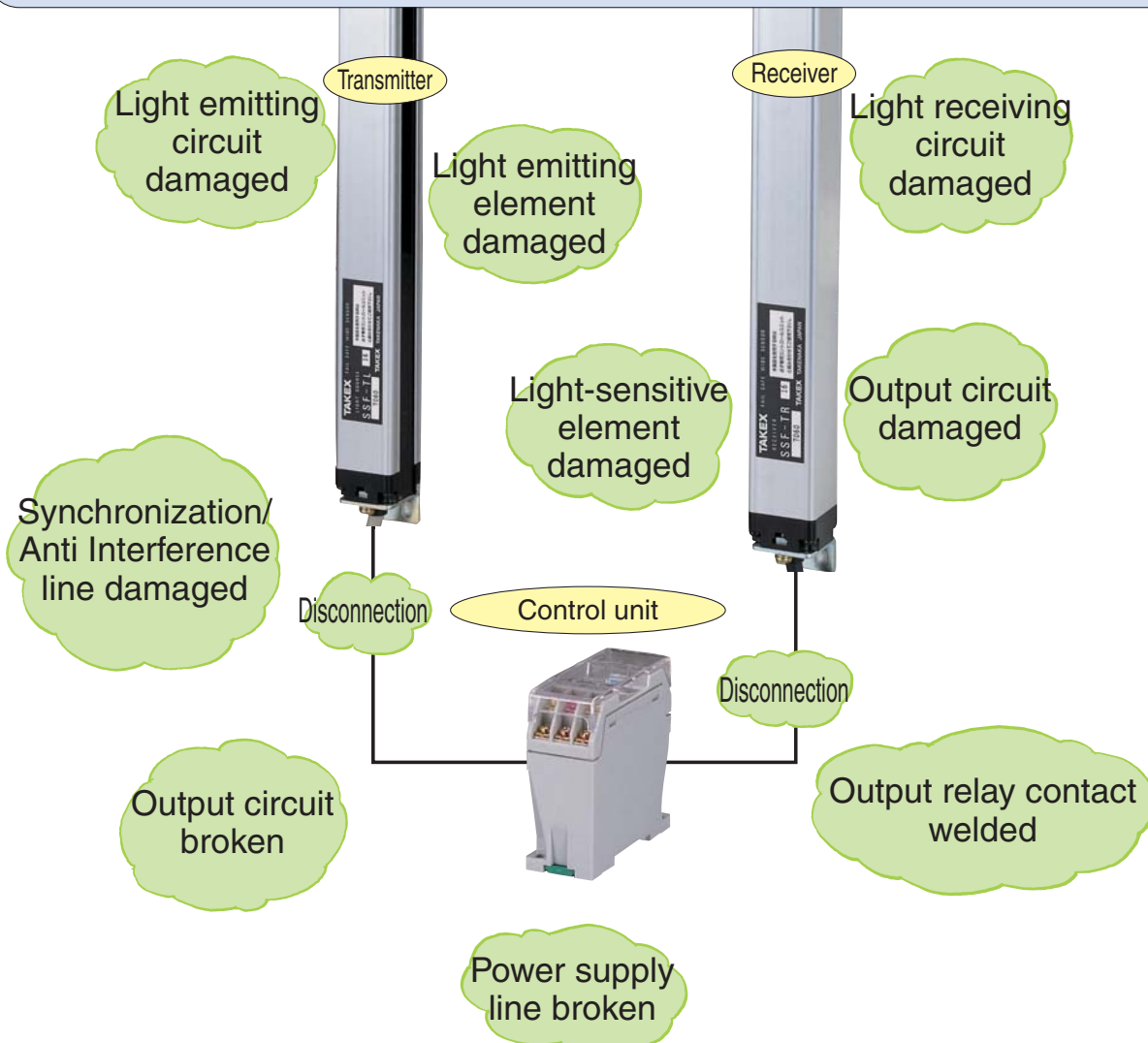

- Safety ensured in the unlikely event of failure  
————— Fail-safe feature
- Enhanced safety with high performance and user-friendliness  
————— Multifunctional
- 20- and 40-mm light axis intervals available  
————— Wide variation

Output relay turns OFF (safe side) when failure occurs

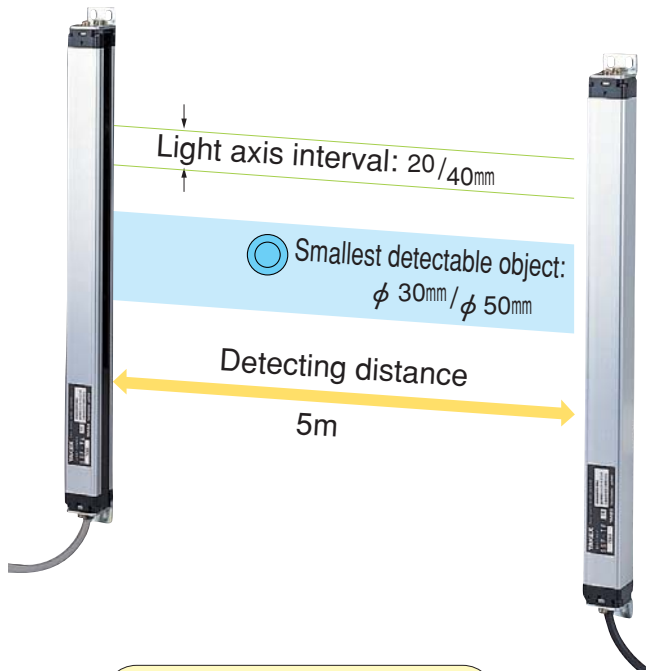



### Light axis alignment indicator for ease of use



Light axis alignment indicator lamps for the top (H) and bottom (L) light axes are provided at the center of the receiver for assistance with light axis adjustment and check.

### 2 sets of sensors mounted adjacently or face-to-face without interference

Anti Interference feature counteracts the installation restrictions and ensures reliability.

### Relay contacts used for all outputs for enhanced fail-safe feature

Contact relays are used for control and lockout outputs. Failure-safe is taken into consideration for failure mode as well.

### Easy maintenance thanks to robust and slim case provided with spatter-resistant plate

Robust aluminum drawn case is employed. Front cover that protects the lenses from scattered oil dust or spatters may be removed for cleaning and replacement.

### Fail-safe automatic sensitivity compensation feature provided

After the light axis alignment is completed, turn the power off once and back on. The automatic sensitivity compensation feature is enabled and the sensitivity is set at the optimum. If the lens is soiled with dirt or dust, the sensitivity is automatically compensated to achieve the optimum sensitivity after the soil is removed.

### CHECK switches provided for simple operation check



The CHECK switches on the control unit allow simple operation check and lockout release check.

### Wide variation

A wide range of sizes from 4 (120mm) to 64 axes (2520 mm) offered for various applications (compatible to supersized machines).

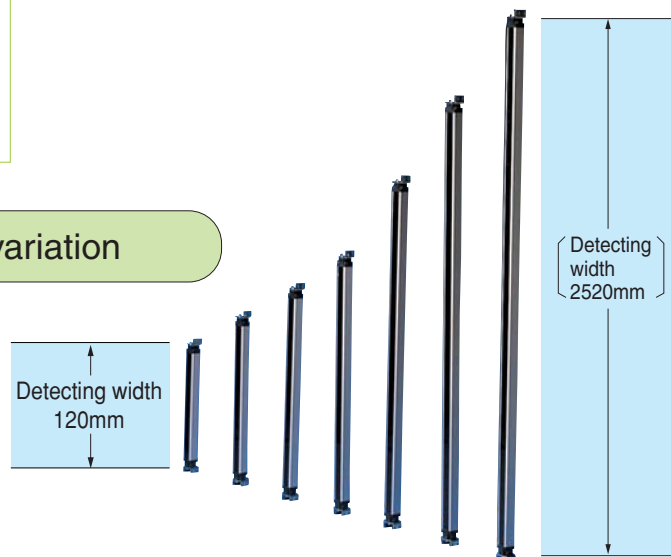

# SSF

## Type

Series name	Detecting distance	Detecting width	Set model No.	No. of light axes	Light axis interval	Detecting object
↑ <b>SSF-T200</b>		140mm	<b>SSF-T8C</b>	8	20mm	Opaque object of $\phi$ 30 min
		300mm	<b>SSF-T16C</b>	16		
		460mm	<b>SSF-T24C</b>	24		
		620mm	<b>SSF-T32C</b>	32		
		780mm	<b>SSF-T40C</b>	40		
		940mm	<b>SSF-T48C</b>	48		
		1100mm	<b>SSF-T56C</b>	56		
		1260mm	<b>SSF-T64C</b>	64		
↑ <b>SSF-T400</b>	5m	120mm	<b>SSF-T404C</b>	4	40mm	Opaque object of $\phi$ 50 min
		280mm	<b>SSF-T408C</b>	8		
		440mm	<b>SSF-T412C</b>	12		
		600mm	<b>SSF-T416C</b>	16		
		760mm	<b>SSF-T420C</b>	20		
		920mm	<b>SSF-T424C</b>	24		
		1080mm	<b>SSF-T428C</b>	28		
		1240mm	<b>SSF-T432C</b>	32		

For prices of the individual transmitter, receiver and special control unit, see the Prize List at the end of the book.

### • Set model description

Transmitter: SSF-TL  }  indicates the number of axes  
 Receiver: SSF-TR  }  
 Control unit: SSF-C

Cord with connector for transmitter: SS-H5L

Cord with connector for receiver: SS-H5R

### • Products with countermeasures provided in the event of faulty operation due to spatter or arc light are available (SSF-T400 Series).

Transmitter: SSF-TL4  -HP

Receiver: SSF-TR4  A-HP

Set model: SSF-T4  AC-HP

### • 2-output type

Products with two 1a contact outputs are available on request.

## Optional Parts

### • Corner reflector

Deflects light at a corner.

Model	Applicable model (*)
SSM-F8N	SSF-T8
SSM-F16N	SSF-T16
SSM-F24N	SSF-T24
SSM-F32N	SSF-T32
SSM-F40N	SSF-T40
SSM-F48N	SSF-T48
SSM-F56N	SSF-T56
SSM-F64N	SSF-T64

(Note) The detecting distance will be reduced to 4m max.

\*May also be used for the SSF-T400 Series. Note the number of axes and the overall length of the reflector.

### • Front cover

Model: SSF-K\*  indicates the number of axes (unified price for all models).

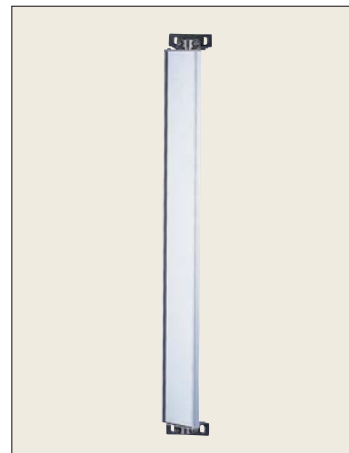

## Rating/Performance/Specification

Series		SSF-T200 series	SSF-T400 series	
Rating/performance	Detection method	Through-beam type		
	Detecting distance	5m max.		
	Detecting object	Opaque object of $\phi$ 30mm min.	Opaque object of $\phi$ 50mm min.	
	Light axis interval	20mm	40mm	
	No. of light axes	(See "Type.")		
	Detecting width			
	Power supply	24V DC $\pm$ 10%		
	Current consumption	300mA max.		
	Control output	Output mode	Output: relay contact 1a (2 relay outputs in series) Rating: 250V 3A AC noninductive load 30V 2A DC noninductive load	
		Operation mode	Activated when light beams of all axes are received	
Response time		Light blocking: 20 ms max / Light reception: 30 ms max.		
Lockout output	Output mode	Output: relay contact 1a Rating: 250V 1A AC noninductive load 30V 1A DC noninductive load		
	Operation mode	ON for normal operation, OFF for failure		
	Response time	50ms or less		
Specification	Light source	Infrared LED (wavelength 880nm)		
	Light-sensitive element	Photo IC		
	Indicator	Transmitter	Circuit failure indicator (Orange) Synchronization failure indicator (Red) RUN indicator (Green) Slave indicator (Orange)	
		Receiver	Top light axis alignment indicator (Green)/Disturbing light indicator (Orange) /Bottom light axis alignment indicator (Green) Operation indicator (Red)/Unstable light reception indicator (Orange) /Stable light reception indicator (Green)	
		Control unit	POWER (Green) OUTPUT (Yellow) SENSOR FAIL (Red) LOCK OUT (Red)	
	Auxiliary functions	Anti Sensitivity feature for adjacent installation, automatic sensitivity compensation		
	Switch	Control unit: CHECK switch		
	Material	Transmitter/receiver: aluminum / Front cover: acrylic Control unit: polycarbonate		
	Connection	Permanently attached cord with connector ( $\phi$ 6.8 4-core cord of 0.2 m in length for transmitter/receiver) Control unit: terminal block type with M3.5 screws		
	mass	Sensor	230g max. -1000g max.	
Control unit		160g max.		
Accessory	Cord with connector (cord length: 5 m), mounting brackets, operation manual			

## Environmental Specification

Ambient light	9000lx max.
Ambient temperature	-10 - +55 °C (non-freezing)
Ambient humidity	35-85%RH (non-condensing)
Vibration	10-55 Hz / 1.5 mm amplitude / 2 hours each in 3 directions
Protective structure	Sensor: IP65 (except for connector) / Control unit: IP40
Dielectric withstanding	1500 VAC for 1 minute
Insulation resistance	500 VDC, 20 M $\Omega$ or higher.

## Optional Parts

- Cord with connector (10 m)
- For transmitter: SS-H10L (gray covering)
- For receiver: SS-H10R (black covering)

## Input/Output Circuit and Connection

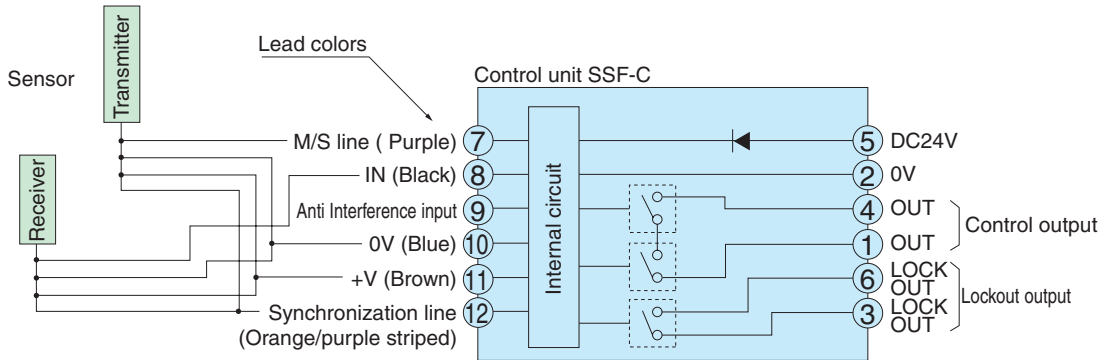

(Circled numbers show pin Nos.)

## Indicators and Operation

The indicators provided for the transmitter, receiver and control unit and their operation are outlined as follows:

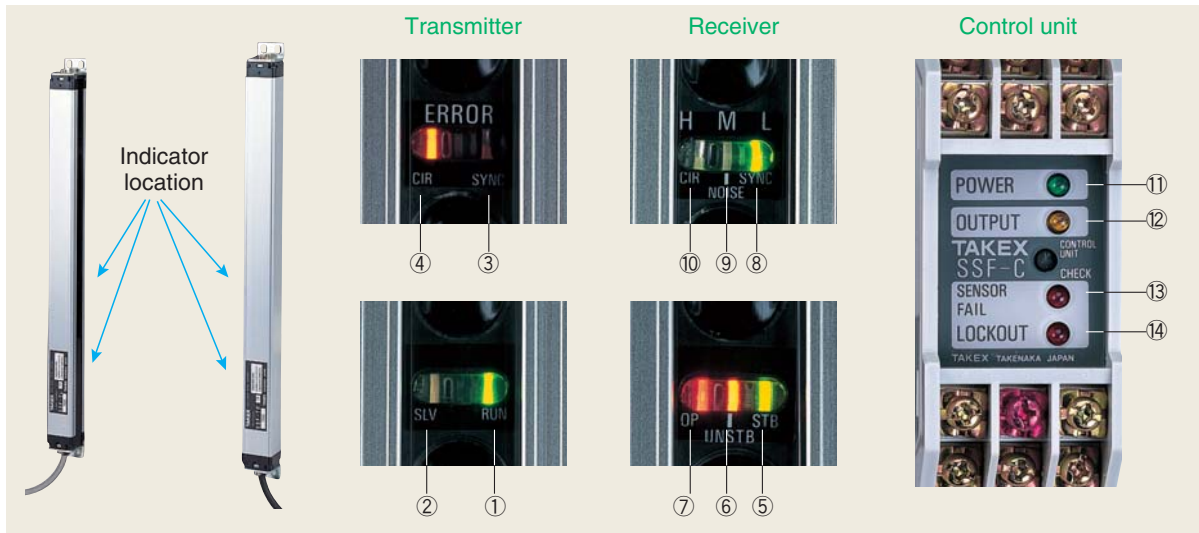

Type	No.	Indicator name	Color	Normal operation	Failure description and indication
Transmitter	①	RUN indicator	Green	Illuminated	Flashes to indicate transmitter failure
	②	Slave indicator	Orange	Illuminated to indicate slave	Flashes to indicate abnormal operation of slave
	③	Synchronization failure indicator	Red	Not illuminated	Flashes to indicate broken synchronization line
	④	Circuit failure indicator	Orange	Not illuminated	Flashes to indicate circuit failure
Receiver	⑤	Stable light reception indicator	Green	Illuminated when beams of all axes are stably received	
	⑥	Unstable light reception indicator	Orange	Illuminated when beam of any axis is unstably received	Flashes to indicate receiver failure
	⑦	Operation indicator	Red	Illuminated when beam of any axis is received/blocked	
	⑧	Bottom light axis alignment indicator	Green	Illuminated when beam of bottom axis is received	Flashes to indicate broken synchronization line/transmitter failure
	⑨	Disturbing light indicator	Orange	Not illuminated	Illuminated when disturbing light/noise is detected
	⑩	Top light axis alignment indicator	Green	Illuminated when beam of top axis is received	Flashes to indicate receiver failure
Control unit	⑪	Power indicator	Green	Illuminated when power is supplied	Illuminated when power supply is cut off
	⑫	Control output indicator	Yellow	Illuminated when beam of any axis is unstably received	—
	⑬	Sensor failure indicator	Red	Not illuminated	Illuminated to indicate sensor failure/unconnected/power short circuit
	⑭	Lockout output indicator	Red	Not illuminated	Illuminated to indicate lockout output

## Connection Examples

- Connection for standalone use

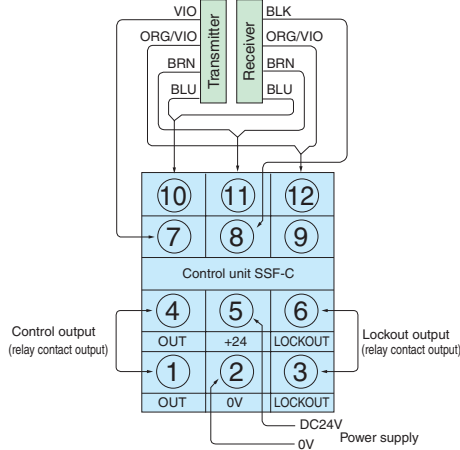

- Connection for Anti Interference

Connect as shown below for adjacent installation of two sets of sensors.

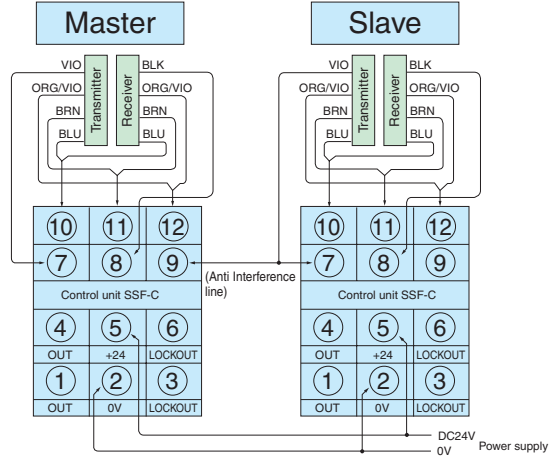

- Be sure to use the same power supply for the master and slave control units.
- The terms master and slave are only used for convenience in distinguishing between two units of the same model that function differently depending on the wiring. The unit with its Anti Interference line connected to Terminal 9 is referred to as the master.
- Do not connect the transmitter and receiver to separate control units.
- For wiring length, see Cord Extension.

## Characteristics (Typical Example)

- Parallel displacement characteristics (Longitudinal) (All models)

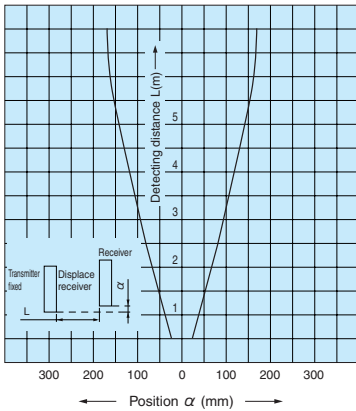

- Parallel displacement characteristics (Horizontal) (All models)

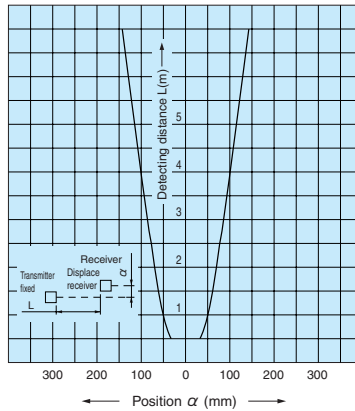

- Operating angle characteristics (All models)

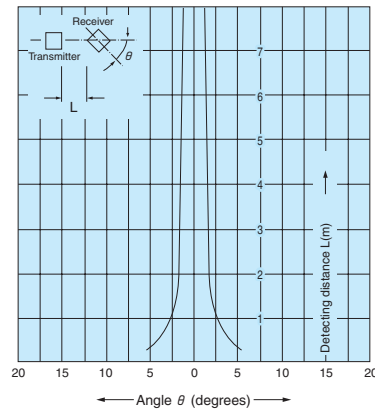

- Smallest detectable object diameter characteristics SSF-T200 series

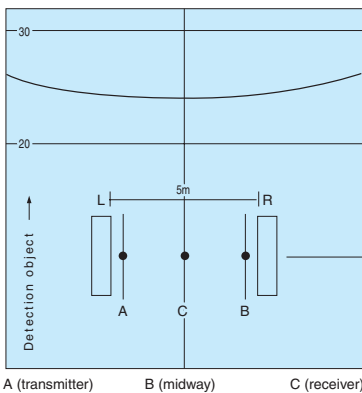

- Smallest detectable object diameter characteristics SSF-T400 series

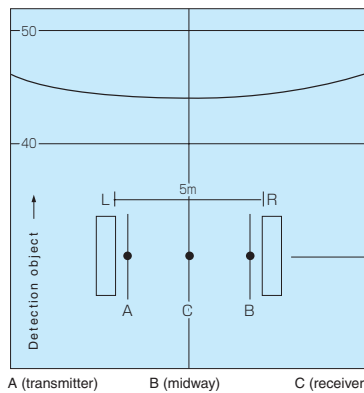

## Indication/Operation Matrix

The operations of the indicators and outputs of the sensor and control unit are as shown in the table below: ● : Illuminated ✪ : Flashing ● : Unilluminated ▲ : Operation depending on situation

Item	Sensor						Control unit					
	Transmitter indicator		Receiver indicator			Indicator	Control output	Lockout output				
Normal operation	Stable light reception	● CIR	● SYNC	● CIR	● NOISE	● SYNC	● POWER	● OUTPUT	● FAIL	● LOCKOUT		
		▲ SLV	● RUN	● OP	● UNSTB	● STB	● POWER	● OUTPUT	● FAIL	● LOCKOUT		
Normal operation	Light blocking	● CIR	● SYNC	▲ CIR	● NOISE	▲ SYNC	● POWER	● OUTPUT	● FAIL	● LOCKOUT		
		▲ SLV	● RUN	● OP	● UNSTB	● STB	● POWER	● OUTPUT	● FAIL	● LOCKOUT		
Failure	Disturbing light (when detected)	● CIR	● SYNC	● CIR	● NOISE	● SYNC	● POWER	● OUTPUT	● FAIL	● LOCKOUT		
		▲ SLV	● RUN	● OP	● UNSTB	● STB	● POWER	● OUTPUT	● FAIL	● LOCKOUT		
Failure	Light emitting element damaged	● CIR	● SYNC	▲ CIR	● NOISE	▲ SYNC	● POWER	● OUTPUT	● FAIL	● LOCKOUT		
		▲ SLV	● RUN	● OP	● UNSTB	● STB	● POWER	● OUTPUT	● FAIL	● LOCKOUT		
Failure	Light sensitive element damaged	● CIR	● SYNC	● CIR	● NOISE	● SYNC	● POWER	● OUTPUT	● FAIL	● LOCKOUT		
		▲ SLV	● RUN	● OP	● UNSTB	● STB	● POWER	● OUTPUT	● FAIL	● LOCKOUT		
Failure	Light emitting circuit damaged	✪ CIR	● SYNC	● CIR	● NOISE	✪ SYNC	● POWER	● OUTPUT	● FAIL	● LOCKOUT		
		▲ SLV	✪ RUN	● OP	✪ UNSTB	✪ STB	● POWER	● OUTPUT	● FAIL	● LOCKOUT		
Failure	Light receiving circuit damaged	● CIR	● SYNC	✪ CIR	● NOISE	● SYNC	● POWER	● OUTPUT	● FAIL	● LOCKOUT		
		▲ SLV	● RUN	✪ OP	✪ UNSTB	✪ STB	● POWER	● OUTPUT	● FAIL	● LOCKOUT		
Failure	Output circuit damaged	● CIR	● SYNC	▲ CIR	▲ NOISE	▲ SYNC	● POWER	● OUTPUT	● FAIL	● LOCKOUT		
		▲ SLV	● RUN	▲ OP	▲ UNSTB	▲ STB	● POWER	● OUTPUT	● FAIL	● LOCKOUT		
Failure	Output line broken	● CIR	● SYNC	● CIR	● NOISE	● SYNC	● POWER	● OUTPUT	● FAIL	● LOCKOUT		
		▲ SLV	● RUN	▲ OP	▲ UNSTB	▲ STB	● POWER	● OUTPUT	● FAIL	● LOCKOUT		
Failure	Transmitter power supply line broken	● CIR	● SYNC	● CIR	● NOISE	✪ SYNC	● POWER	● OUTPUT	● FAIL	● LOCKOUT		
		● SLV	● RUN	✪ OP	✪ UNSTB	✪ STB	● POWER	● OUTPUT	● FAIL	● LOCKOUT		
Failure	Receiver power supply line broken	● CIR	● SYNC	● CIR	● NOISE	● SYNC	● POWER	● OUTPUT	● FAIL	● LOCKOUT		
		▲ SLV	● RUN	● OP	● UNSTB	● STB	● POWER	● OUTPUT	● FAIL	● LOCKOUT		
Failure	Synchronization line broken	● CIR	● SYNC	● CIR	● NOISE	✪ SYNC	● POWER	● OUTPUT	● FAIL	● LOCKOUT		
		▲ SLV	● RUN	✪ OP	✪ UNSTB	✪ STB	● POWER	● OUTPUT	● FAIL	● LOCKOUT		
Failure	Anti Interference line broken (slave)*	● CIR	✪ SYNC	● CIR	● NOISE	✪ SYNC	● POWER	● OUTPUT	● FAIL	● LOCKOUT		
		✪ SLV	✪ RUN	✪ OP	✪ UNSTB	✪ STB	● POWER	● OUTPUT	● FAIL	● LOCKOUT		
Failure	Relay contact welded	● CIR	● SYNC	● CIR	● NOISE	● SYNC	● POWER	● OUTPUT	● FAIL	● LOCKOUT		
		▲ SLV	● RUN	▲ OP	▲ UNSTB	▲ STB	● POWER	● OUTPUT	● FAIL	● LOCKOUT		
Failure	Circuit damaged	● CIR	● SYNC	● CIR	● NOISE	● SYNC	● POWER	● OUTPUT	● FAIL	● LOCKOUT		
		▲ SLV	● RUN	▲ OP	▲ UNSTB	▲ STB	● POWER	● OUTPUT	● FAIL	● LOCKOUT		
Failure	Power supply line broken	● CIR	● SYNC	● CIR	● NOISE	● SYNC	● POWER	● OUTPUT	● FAIL	● LOCKOUT		
		● SLV	● RUN	● OP	● UNSTB	● STB	● POWER	● OUTPUT	● FAIL	● LOCKOUT		
Failure	Power supply cut off	● CIR	● SYNC	● CIR	● NOISE	● SYNC	● POWER	● OUTPUT	● FAIL	● LOCKOUT		
		● SLV	● RUN	● OP	● UNSTB	● STB	● POWER	● OUTPUT	● FAIL	● LOCKOUT		

(Note) "Locked" refers to a state in which the output relay stays open due to circuit failure.

(Note) When the output circuit is damaged, the control output stays open.

\*When the Anti Interference line is broken in the master/slave configuration, the indicator on the slave flashes and the slave control output relay opens.

## ■ Control Unit Operation and Output

The control unit outputs control and lockout signals depending on the detection by sensor and of different types of failure.

### ● Control output

The control unit has duplicate circuits and the control output is composed of two output relays connected in series.

#### Contact closed

- When light beams of all sensor axes are received (normal operation)

#### Contact open

- When light beam of any axis is blocked
- When control unit lockout has been tripped
- When circuit damage or disconnection has occurred in components
- When power has been supplied with the sensor wired in a wrong way
- When power supply line has been broken
- When the power supply, GND, detection output, synchronization or Anti Interference line, etc. has been broken
- When the sensor output line has been short-circuited to the sensor power supply line (+V or 0 V) of the control unit

### ● Lockout output

Lockout is a feature that forces the control output relay to stay open when any internal failure has been detected.

The control unit SSF-C has completely duplicated internal circuitry and any inconsistency found is regarded as failure, which trips lockout. In addition to lockout, the contact is opened for 2 seconds after power-up or when power supply line to the control unit has been broken.

#### Condition of lockout

- (1) Inconsistency between the two control output relays  
When either of the output relays does not operate due to welding of contact
- (2) Inconsistency between the duplicate circuits  
When the operation of the two circuits do not agree due to failure in output circuit components of the control unit

#### Notes on lockout release

Lockout can be released by pressing the CHECK switch on the control unit.

Before releasing lockout, identify and eliminate the cause of the lockout.

If lockout cannot be released by pressing the CHECK switch, the control unit output circuit may be damaged or the output relay may be welded. Replace the control unit.

Use the lockout output for monitoring. Do not use the output for control.

For control, be sure to use the control output.

## For Correct Use



- Be sure to follow the instructions in the operation manual provided for correct use of the product.
- This sensor cannot be used as a press safety device or other safety device for protection of human body that requires conformity to domestic or overseas standards or certification concerning protection of human body. Use for such purposes may lead to death or serious injury in the unlikely event of failure.
- This sensor is intended for detection of ingress of human body or object passing through an arbitrary point not involving protection of human body or safety.
- When using this sensor for safety purposes, ensure safe operation of the system as a whole including detection and control.

## Cord Extension

To extend the cord, use wires of at least 0.5 mm<sup>2</sup> and limit the length as follows:

- Basic wiring : within 25 m between the transmitter/receiver and control unit (Figure 1)
- Synchronization wiring : within 50 m between transmitter and receiver (Figure 2)
- Anti Interference wiring : within 25 m between the two transmitters (Figure 3)
- Power supply wiring for M/S wiring : within 25 m between the two control units (Figure 4)

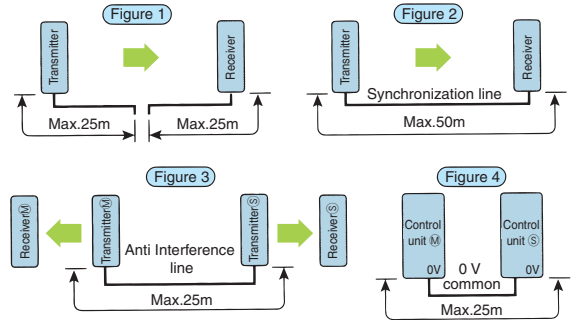

## Notes on installation

- When installing the sensor, make sure that the ends of the transmitter and receiver with the cord are oriented either upward or downward. The sensor does not function if the transmitter and receiver are not oriented the same way.
- The tightening torque for installing the sensor should be up to 2 N · m. The tightening torque for installing the control unit with screws should be up to 0.78 N · m.

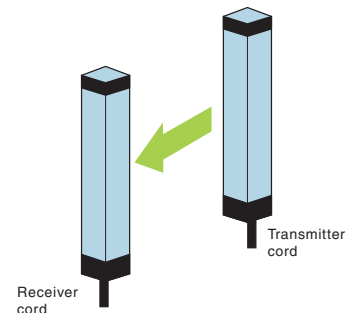

- Any reflecting object (wall, floor, machine, etc.) within the effective range between the transmitter and receiver may allow the light of the sensor to go around the detection object, which is supposed to block the light, and reach the receiver. Choose the installation location carefully (Any glossy object such as stainless steel in the surrounding area must be at least 30 cm away from the center of the light transmission and reception area both vertically (up and down) and horizontally (left and right)).
- Do not install the sensor in a place subject to steam, large amount of dust or direct exposure to water or rain.

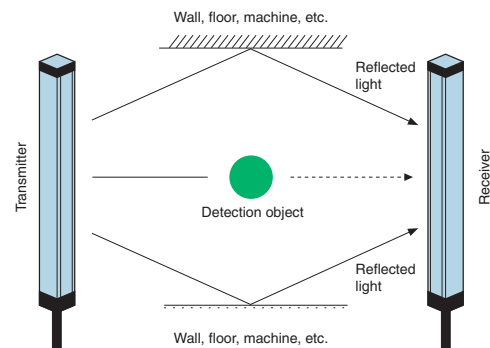

## Dimensions (in mm)

### SSF-T200 Series transmitter/receiver

CAD

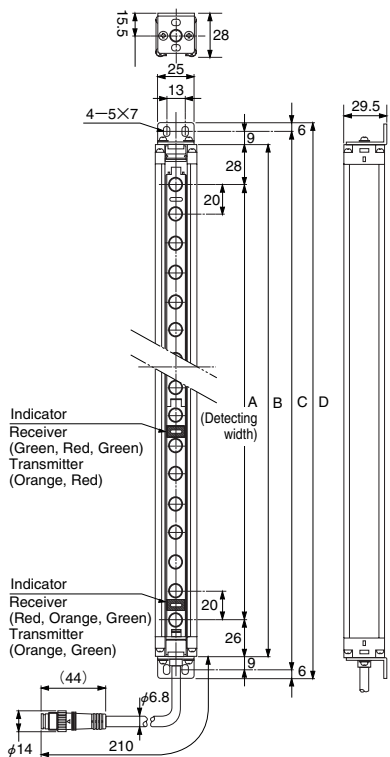

• Dimensions of portions (in mm)

Model	A	B	C	D
SSF-T8	140	194	212	224
SSF-T16	300	354	372	384
SSF-T24	460	514	532	544
SSF-T32	620	674	692	704
SSF-T40	780	834	852	864
SSF-T48	940	994	1012	1024
SSF-T56	1100	1154	1172	1184
SSF-T64	1260	1314	1332	1344

### SSF-T400 Series transmitter/receiver

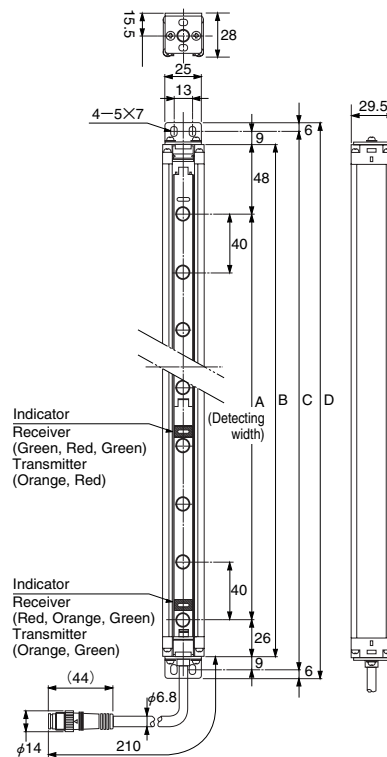

• Dimensions of portions (in mm)

Model	A	B	C	D
SSF-T404	120	194	212	224
SSF-T408	280	354	372	384
SSF-T412	440	514	532	544
SSF-T416	600	674	692	704
SSF-T420	760	834	852	864
SSF-T424	920	994	1012	1024
SSF-T428	1080	1154	1172	1184
SSF-T432	1240	1314	1332	1344
SSF-T436	1400	1474	1492	1504
SSF-T440	1560	1634	1652	1664
SSF-T444	1720	1794	1812	1824
SSF-T448	1880	1954	1972	1984
SSF-T452	2040	2114	2132	2144
SSF-T456	2200	2274	2292	2304
SSF-T460	2360	2434	2452	2464
SSF-T464	2520	2594	2612	2624

### Model SSF-C (Control unit)

CAD

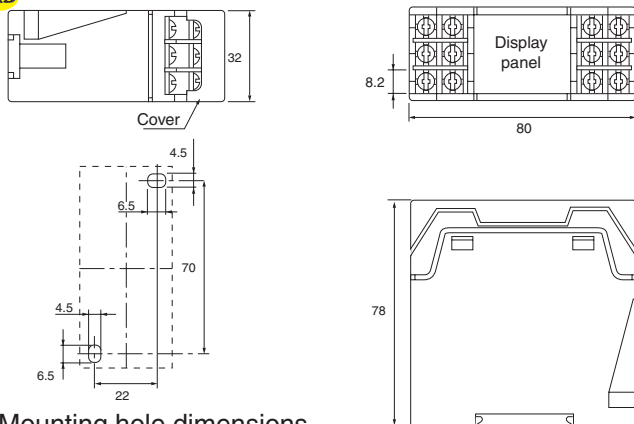

Mounting hole dimensions

### Cord with connector (accessory)

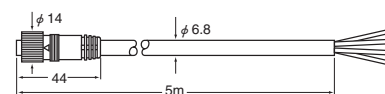

SS-H5L (covering: gray)  
SS-H5R (covering: black)