



- For detection of marks on edge of transparent or translucent film
- Both Light-ON and Dark-ON outputs available
- U-shaped sensor requiring no light axis alignment, eliminates the possibility of misalignment caused by vibration
Distance: 10 mm fixed
- Light reception indicator and easy-to-use sensitivity adjustment provided, also excellent resistance to noise

Type

Detection method	Detection interval	Model	Light source	Operation mode	Output mode
 U-shaped through-beam	10 mm fixed	MU10NR	Red LED	Light-ON and Dark-ON 2 outputs (by 2 output leads)	Current output Voltage output
		MU10N	Green LED		

- MU10NR uses a red LED as the light source, which allows detection of black register mark printed on opaque paper. Applications may include detection of paper double feed on labeling machines, etc.
- MU10N uses a green LED as the light source, which allows detection of register marks printed on transparent or translucent paper with transmission factor of 10-100%.

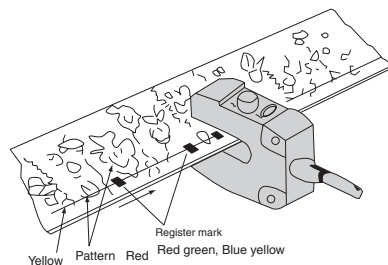

Detection Capability

- Reference for selection of model

Detection object	Film sheet with transmission factor of 10-100%					Film sheet with transmission factor of 10% or lower						
	Mark color											
Model	赤	黒	茶	紺	緑	青	赤	黒	茶	紺	緑	青
MU10N	○	○	○	○	△	○	—	—	—	—	—	—
MU10NR	—	—	—	—	—	—	×	○	×	○	○	○

- : detectable
- △: may be detectable depending on shade
- ×: unlikely to be detectable
- : inappropriate application

Detection may not succeed depending on the shading. Be sure to provide samples.

Sensitivity Adjustment

* The following example shows the procedure to adjust for light blocking condition with a register mark. For light reception condition with register marks, adjust in a reverse manner.

1. Turn the sensitivity adjustment counterclockwise to the minimum sensitivity.
2. With no mark present, turn up (clockwise) the sensitivity adjustment gradually from the minimum position and find the point at which the indicator is illuminated (Point b).
3. With the mark present, turn down (counterclockwise) the sensitivity adjustment gradually from the maximum position and find the point at which the indicator is illuminated (Point a). If the indicator is not illuminated even at the maximum, the maximum is regarded as Point a.
4. Set the adjustment at midway between Points a and b.

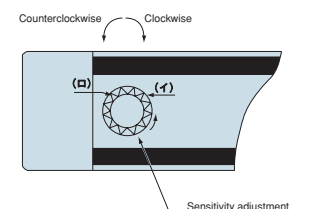

Rating/Performance/Specification

	Type	Red LED type	Green LED type	
	Model	MU10NR	MU10N	
Rating/performance	Detection method	U-shaped through-beam		
	Detection interval (between transmitter and receiver)	10 mm fixed		
	Power supply	12 – 24 VDC ±10% Ripple: 10 % max.		
	Current consumption	35 mA max.		
	Output mode	Current output/Voltage output (Rating): Current output: sink current 100 mA (30 VDC) max. Voltage output: output impedance 4.7 kΩ		
	Operation mode	Light-ON/Dark-ON	2 outputs (by 2 output leads)	
	Response time	3 ms max.		
Specification	Light source	Red LED (680nm)	Green LED (570nm)	
	Sensitivity adjustment	Provided		
	Indicator	Light reception indicator (red LED)		
	Material	Polycarbonate		
	Connection	Permanently attached cord (outer diameter: dia.6) 0.3 mm ² x 4 cores, 3 m		
	Mass	220 g max.		

Environmental Specification

Environment	Ambient light	3,000 lx max.
	Ambient temperature	-10 - +55 °C (non-freezing)
	Ambient humidity	35-85%RH (non-condensing)
	Protective structure	IP40
	Vibration	10-55 Hz / 1.5 mm amplitude / 2 hours each in 3 direction
	Shock	1000 m/s ² / 2 times each in 3 directions
	Dielectric withstanding	1,500 VAC for 1 minute
	Insulation resistance	500 VDC, 20 MΩ or higher

• Applicable power supply unit

PS Series
High capacity of
200 mA at 12 VDC

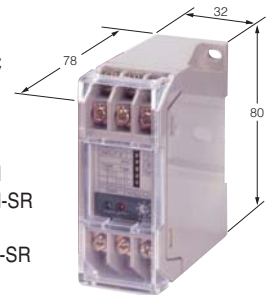

(General-purpose type) PS3N
PS3N-SR
(Multifunctional type) PS3F
PS3F-SR

Input/Output Circuit and Connection

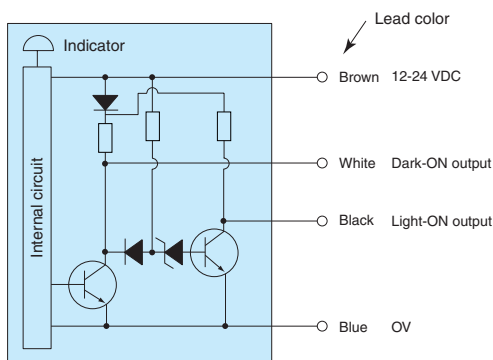

Dimensions (in mm)

