



- Thin red laser beam allows highly-accurate detection

- Minute object detected at long distance
- Wide variety of models for different detecting distances and detection objects
- Simple adjustment with red spot
- Class 1 and 2 models available

- Reflective type (LD-S33R)

- 0.5 mm mark detected at long distance of 300 mm
- Small-field beam allowing detection through gaps and small holes
- Light emission stop function provided

Take safety measures according to the operation manual.

### Type

Detection method	Detecting distance	Model	Detection object	Operation mode	Output mode
 Through-beam type	20m	<b>LD-T20R</b>	Opaque objects of $\phi 20$ mm or larger	Light-ON/ Dark-ON selectable (with switch)	Open collector
	15m	<b>LD-T20R-P2</b>	Opaque objects of $\phi 2$ mm or larger		
	7m	<b>LD-T20R-P1</b>	Opaque objects of $\phi 1$ mm or larger		
	3m	<b>LD-T20R-P05</b>	Opaque objects of $\phi 0.5$ mm or larger		
	0.7m	<b>LD-T20R-P03</b>	Opaque objects of $\phi 0.3$ mm or larger		
	20m	<b>LD-T20R-C1</b>	Opaque objects of $\phi 20$ mm or larger		
	10m	<b>LD-T20R-C1-P2</b>	Opaque objects of $\phi 2$ mm or larger		
	5m	<b>LD-T20R-C1-P1</b>	Opaque objects of $\phi 1$ mm or larger		
 Limited reflection type	200~400mm	<b>LD-S33R</b>	0.5mm min. (black mark on white background) Detecting distance 300mm		NPN open collector output

- PNP output type

PNP output types are available for all models.

PNP output type models are identified by "PN" at the end of model number.

The rating/performance other than the output is the same as those of NPN types.

### Optional parts

Type	Model	Applicable model	Shape, etc.
Cord with M8 connector	<b>FBC-4R2S</b>	For M8 connector type	Straight with 4-core cord of 2 m (transmitter/receiver)
	<b>FBC-4R2L</b>		Angled with 4-core cord of 2 m (transmitter/receiver)
Protective cover	<b>G-MTB2</b>	For through-beam LD-T20R	Rigid protective cover doubling as mounting bracket. See "Dimensions (optional parts)."

## Rating/Performance/Specification

Model	NPN type	LD-T20R	LD-T20R-C1	LD-S33R
	PNP type	LD-T20RPN	LD-T20RPN-C1	—————
Detection method		Through-beam type		Limited reflection type
Power supply		12 - 24V DC ±10% / Ripple 10% max.		
Current consumption	NPN type	Transmitter: 20 mA max. Receiver: 20 mA max.		38mA以下
	PNP type	Transmitter: 20 mA max. Receiver: 25 mA max.		—————
Output mode	Control output	NPN open collector output Rating: sink current 100 mA (30 VDC) max.		NPN open collector 2 outputs Rating: sink current 100 mA (30 VDC) max.
		PNP open collector output Rating: source current 100 mA (30 VDC) max.		
	Stability output	NPN open collector output Rating: sink current 50 mA (30 VDC) max.		—————
		PNP open collector output Rating: source current 50 mA (30 VDC) max.		—————
Operation mode		Light-ON/Dark-ON selectable		
Response time		0.5ms max.		
Operating angle		30° (at receiver)		—————
Spot diameter		—————		About 2 mm at 300 mm
Smallest detectable mark width		—————		0.5 mm (black mark on white background) at 300 mm
Light source (light wavelength)		Red semiconductor laser (650 nm) Class 2	Red semiconductor laser (650 nm) Class 1	Red semiconductor laser (650 nm) Class 2
Indicator		Transmitter: power indicator (green LED) Receiver: operation indicator (red LED) Stability indicator (green LED)		Operation indicator (red LED) Stability indicator (green LED)
Volume		SENS: sensitivity adjustment (at receiver)		8-turn sensitivity adjustment
Switch		Light-ON/Dark-ON selector switch provided		
Short circuit protection		Provided (for control output only)		Provided
Material	Case	Polyarylate		Body: zinc die-cast / Aluminum head: heat-resistant ABS / Display: polycarbonate
	Lens	Acrylic		Glass
Connection		Permanently attached cord(outer dimension: dia. 4.2) Transmitter: 0.3 sq. 2 core 2 m length (gray) Receiver: 0.2 sq. 4 core 2 m length (black) -J type: M8 connector connection		Permanently attached cord (outer dimension: dia. 4.5) 0.2 sq. 5 core 2 m length
Mass		Permanently attached cord type: about 80 g (transmitter/receiver) / -J type: about 25 g (transmitter/receiver)		Approx. 300g
Notes		Mounting bracket, operation manual, warning label, instruction label		

## Environmental Specification

	LD-T20R	LD-S33R
Ambient light	5,000 lx max.	Sunlight: Light receiving surface illumination 10,000 max. Incandescent lamp: receiving surface illumination 3,000 lx max.
Ambient temperature	-10 - +55°C	
Ambient humidity	35 - 85%RH	
Protective structure	IP67	IP66
Vibration	10 - 55 Hz / 1.5 mm amplitude / 2 hours each in 3 direction	
Shock	500 m/s <sup>2</sup> / 3 times each in 3 directions	100 m/s <sup>2</sup> / 3 times each in 3 directions
Dielectric withstanding	1,000 VAC for 1 minute	
Insulation resistance	500 VDC, 20 MΩ or higher	

- Applicable power supply unit  
PS Series  
High capacity of 200 mA at 12 VDC



- (General-purpose type) PS3N  
PS3N-SR
- (Multifunctional type) PS3F  
PS3F-SR

## Input/Output Circuit and Connection

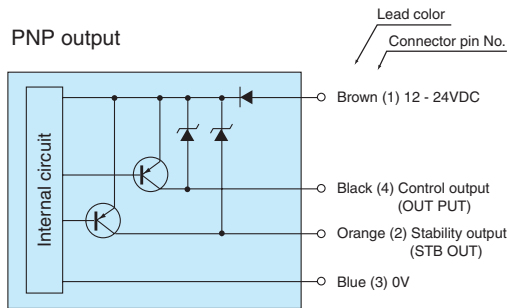
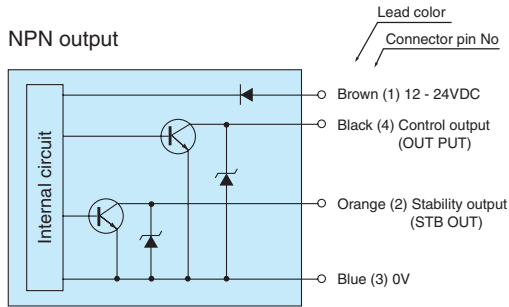

- The output transistor turns off when load short circuit or overload occurs. Check the load and turn the power back on.
- The stability output is not provided with short circuit protection.

## Switching between Light-ON and Dark-ON

The operation mode selector switch is provided on the receiver.

Turn to L for Light-ON mode and D for Dark-ON mode.

Light-ON mode

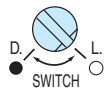

Dark-ON mode

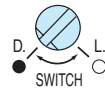

## M8 connector type (-J)

Pin assignment

(Receiver)

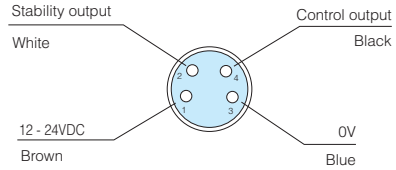

The colors show lead colors for use in combination with the optional cord with M8 connector.

(Transmitter)

Lines other than Lines 1 (brown) and 3 (blue) are unused.

## Stability output

The stability output can be used to check for reduction of the light intensity level along with any change in the operating environment or operation over time or to perform initial check of the operation. When two consecutive detections have occurred with the intensity of light detected exceeding the operation level but not reaching 120 % of the level (range allowing stable operation), the stability signal is output when the control output is deactivated.

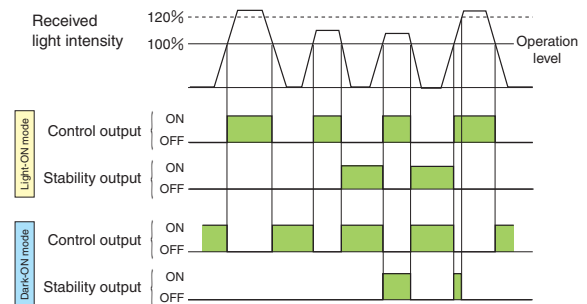

## Characteristics (Typical Example)

### • Directional characteristics

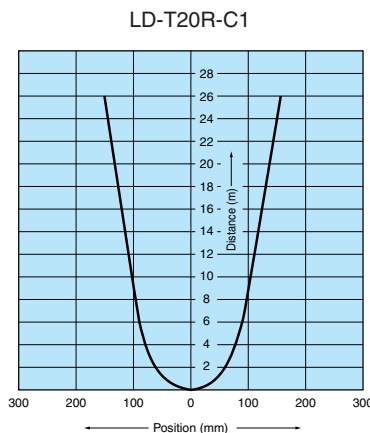
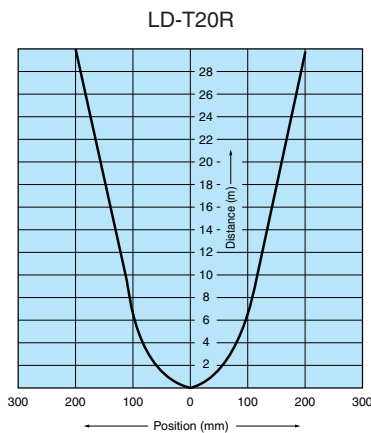

### • Temperature characteristics

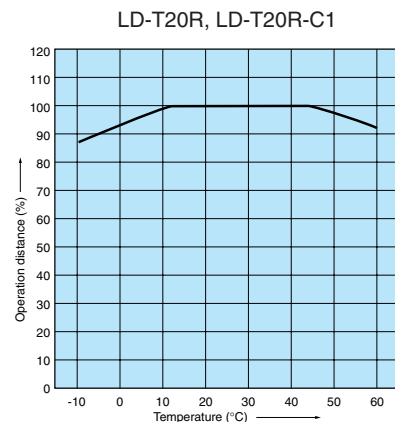

## Panel Indication

LD-S33R

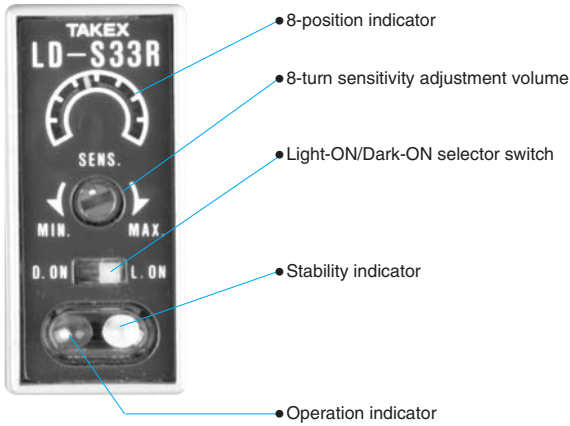

## Input/Output Circuit and Connection

LD-S33R

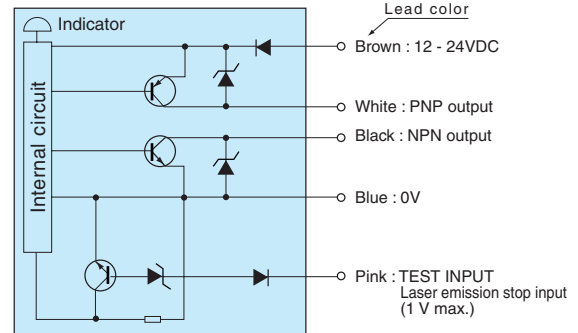

Slow starter circuit is provided for laser emission. The laser light is illuminated about 0.5 seconds after power-up or reset of short circuit caused by emission stop input.

The output transistor turns off when load short circuit or overload occurs. Check the load and turn the power back on.

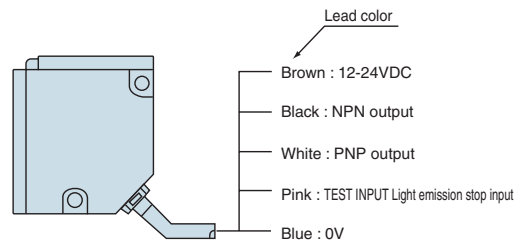

## Using Light Emission Stop Function (LD-S33R only)

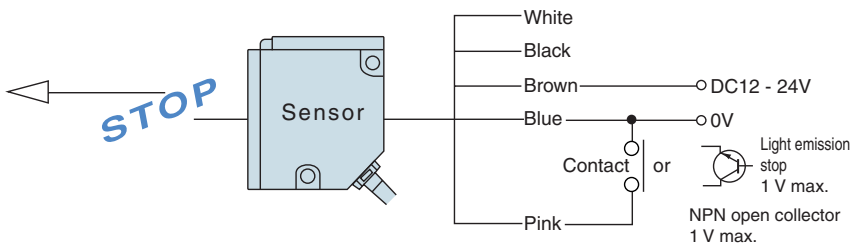

Short-circuiting the blue and pink leads of the transmitter stops the laser light emission at arbitrary timing.

## Activation Area Characteristics (Typical Example)

LD-S33R

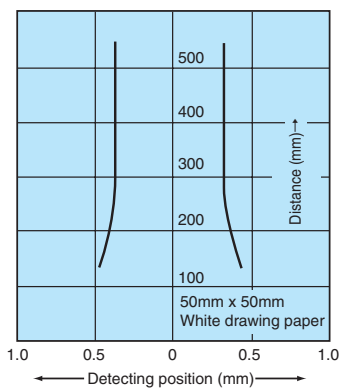

## Sample Applications

### Highly-accurate detection achieved with extra thin beam

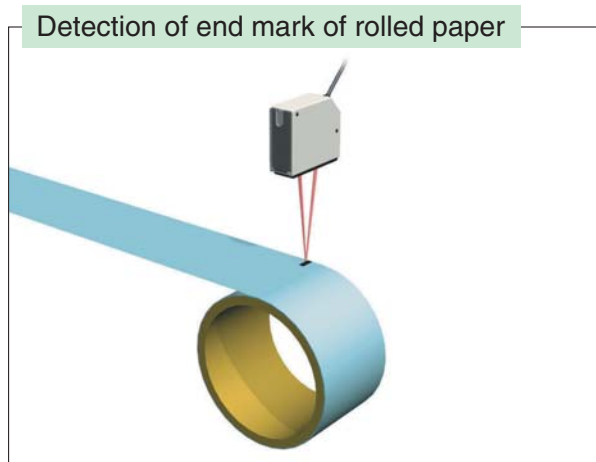
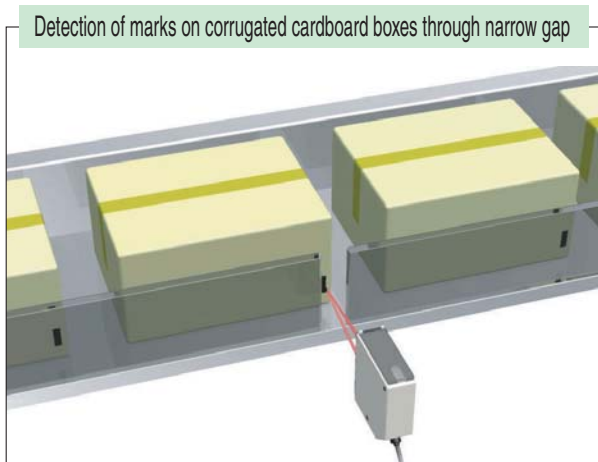
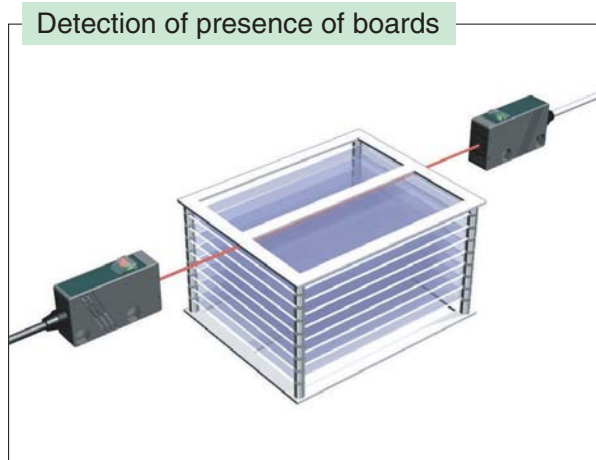
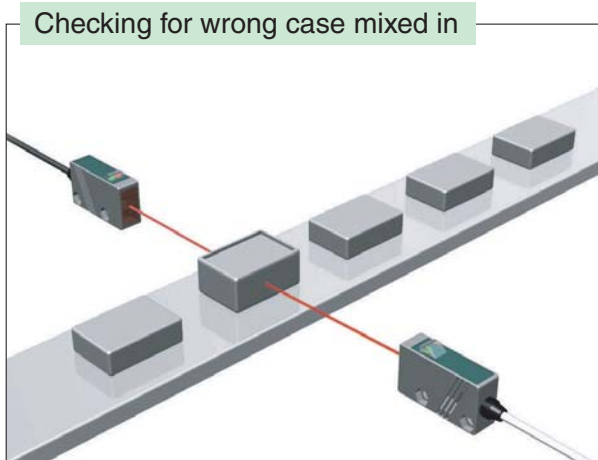

## For Correct Use



- Do not use the product for for the protection of human body.
- When using the product for safety purposes, ensure "System-Wide" safety with the control system as a whole as well as the detection.
- This product is not explosion proof.

- The semiconductor laser used in this product falls under the following class as defined in JIS C 6802 "Safety of Laser Products."
  - Class 1 (Intrinsically safe under the rationally predictable operation conditions)
  - Class 2 (Emits visible radiation from which the eyes are generally protected by the aversion reactions)
- This product employs a parallel beam of laser and care should be taken not to allow the laser light to enter human eye. Never look into the laser radiation outlet of the transmitter connected to power supply. Looking straight into the laser light may damage the eye.
- This product is provided with warning and instruction labels as shown below for notifying and alerting the operator of the sensor of the degree of danger. After the product has been installed, attach the labels in prominent locations on the sensor.

- The radiated laser beam is elliptic due to the characteristics of semiconductor laser. In addition, diffraction pattern is generated due to optical diffraction phenomenon.



- Be notified that this product uses semiconductor laser and is prone to deterioration due to surge current or static electricity.
- The laser diode is equipped with a circuit that maintains the same light intensity level by increasing the current if it becomes dark. For this reason, allow sufficient margin in the capacity of the power supply.
- Always avoid use in which the power is turned on and off consecutively.
- Be sure to turn off the power before moving including mounting and removing or repairing.

#### Warning label



#### Instruction level

•Class 2

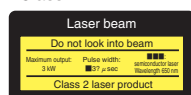

•Class 1.

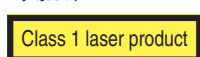

## Dimensions (in mm)

### LD-T20R (-C1) Series

CAD

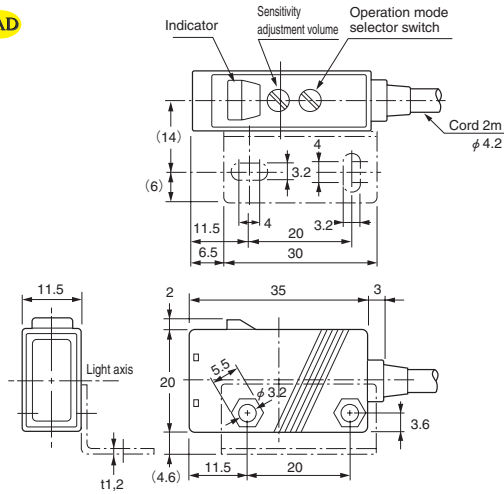

### M8 connector type (-J type)

CAD

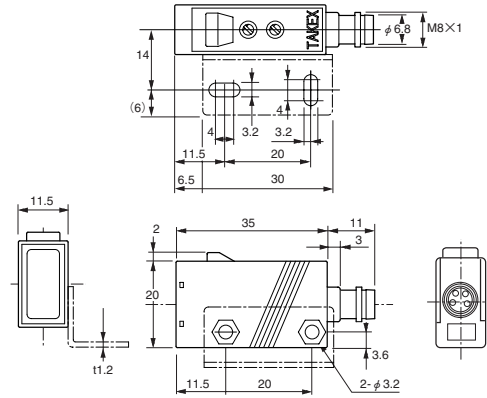

The figures above show the receiver. The transmitter has a different panel side.

### LD-S33R

CAD

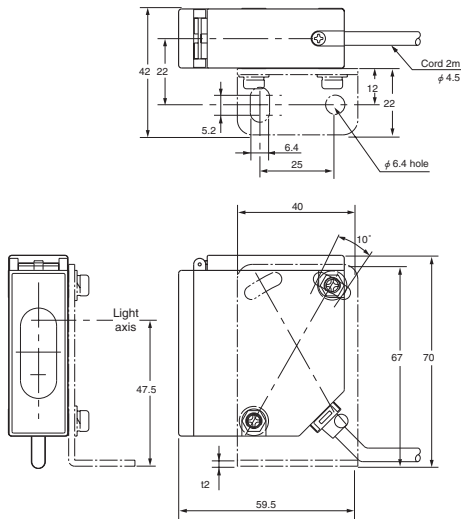

With mounting bracket attached

## Dimensions (Optional parts) (in mm)

### G-MTB2

CAD

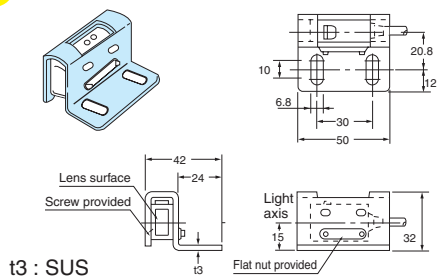

t3 : SUS

### FBC-4R2S(straight)

CAD

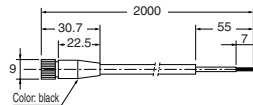

### FBC-4R2L(angled)

CAD

