



● Programmable control capability provides complex detection and operation

- Combinations of logic codes, which represent 8 combinations of input active states of sensors, and function codes, which represent 8 types of programmed output operations, namely (1) 2-channel, (2) AND, (3) OR, (4) XOR, (5) LATCH, (6) CL.AND, (7) GATE MEMORY and (8) Edge control provide 64 types of complex detection and operation. Complex operations that conventionally required the design of complex control circuits or more than one control unit are now available in a single unit.

■ Type

Model	Power supply	Operation mode	Output mode	Timer feature	Power supplied to sensor
IP2F	AC 100~120V / AC 200~240V ±10% · 50 / 60Hz	Selectable with digital switch (see the description of operations for codes) Timer switching	2 relay contacts (1a) 1 open collector	Provided	12 VDC, 100 mA max.

■ Panel Description

Power indicator
Illuminated when power is supplied

Output 1 operation indicator

Output 2 operation indicator
(Illuminated when Output 1/2 is activated)

Function code
Rotary digital switch for enabling one of the preprogrammed 8 output operations

Logic code
Rotary digital switch for enabling one of the preprogrammed sensor input states (activated for ON <L> or for OFF <H>)

Delay time adjustment (*)
Turning clockwise increases duration

Delay time range selector (*)
Selects between 0.1-1 second, 1-10 seconds and timer disabled

Timer selector (*)
Selects between on-delay, off-delay and one-shot

(Items marked with * are applicable to Output 1 only.)

- OND (On-delay)···Cancels signals that are shorter than the set duration.
- OFD (Off-delay)···Extends output signals by the set duration.
- OST (One-shot)···Provides signals of the set duration starting at detection

Rating/Performance/Specification

Type	IP2F															
Power supply	AC100~120V / AC200~240V ±10% 50 / 60Hz															
Power consumption	3 VA max.															
Rating/performance	Operation mode	Selectable with digital switches *1	Timer function selectable (applicable to Output 1 only) (between on-delay, off-delay, one-shot, timer disabled) Delay time: 0.1-1 s, 1-10 s													
	Output mode	2 relay output (1a x 2) 1 open collector output	Rating: 5 A (250 VAC) resistance load Rating: 50 mA (30VDC) max.													
	Input mode	2 inputs 1 external gating input														
	Power supplied to sensor	12VDC ±1V 100mA														
	External gating	Contact input														
	Response time	Relay contact output	25 ms max.													
		Open collector output	0.5 ms max.													
	Indicator	P.L.: power indicator (green LED) OUT1: Output 1 indicator (red LED) OUT2: Output 2 indicator (red LED)														
	Volume (VR)	TIME: delay timer adjustment (0.1-1 s/1-10 s variable)														
	Specification	Switch (SW)	<ul style="list-style-type: none"> • CODE: digital switch (rotary, 2 digits) <table border="0"> <tr> <td>Digit 1: logic code</td> <td rowspan="2">} *1</td> </tr> <tr> <td>Digit 2: function code</td> </tr> </table> • Timer switch <table border="0"> <tr> <td>1-10 sec: 1-10 s variable</td> <td rowspan="3">(with volume mentioned above)</td> </tr> <tr> <td>0.1-1 sec: 0.1-1 s variable</td> </tr> <tr> <td>NON T.: timer disabled</td> </tr> </table> • Operation mode selector switch <table border="0"> <tr> <td>ON.D</td> <td>·····On-delay</td> </tr> <tr> <td>OF.D</td> <td>·····Off-delay</td> </tr> <tr> <td>OST</td> <td>·····One-shot</td> </tr> </table> 	Digit 1: logic code	} *1	Digit 2: function code	1-10 sec: 1-10 s variable	(with volume mentioned above)	0.1-1 sec: 0.1-1 s variable	NON T.: timer disabled	ON.D	·····On-delay	OF.D	·····Off-delay	OST	·····One-shot
Digit 1: logic code		} *1														
Digit 2: function code																
1-10 sec: 1-10 s variable		(with volume mentioned above)														
0.1-1 sec: 0.1-1 s variable																
NON T.: timer disabled																
ON.D		·····On-delay														
OF.D	·····Off-delay															
OST	·····One-shot															
Case material	Resin															
Connection	Plug-in terminal block (with 3.5 mm screws)															
Mass	450 g max.															
Notes	*1 See Logic Codes (Digit 1) and Function Codes (Digit 2) for details of operation. • Terminal block (TB 14) provided.															

Environmental Specification

Environment	Ambient temperature	-10 - +55 °C (non-freezing)
	Ambient humidity	35-85%RH (non-condensing)
	Vibration	10-55 Hz / 1.5 mm amplitude / 2 hours each in 3 direction
	Shock	1000 m/s ² / 2 times each in 3 directions
	Dielectric withstanding	1500 VAC for 1 minute
	Insulation resistance	500 VDC, 20 MΩ or higher

IP2F

Input Circuit and External Gating

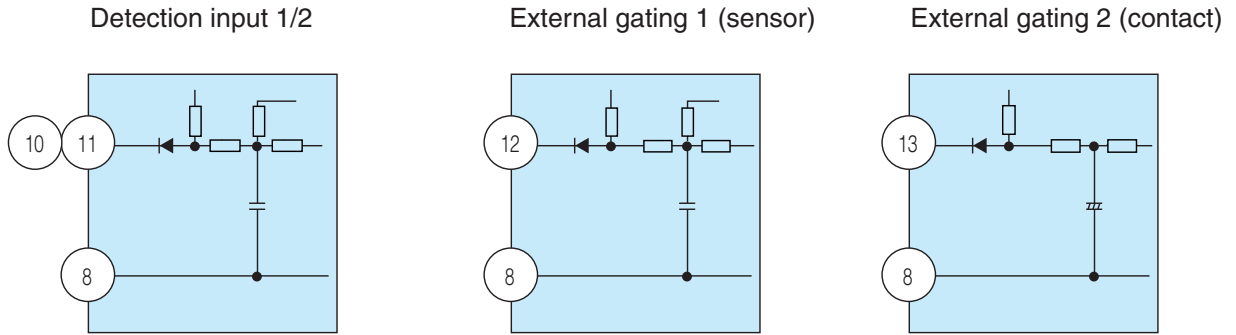

Output Circuit

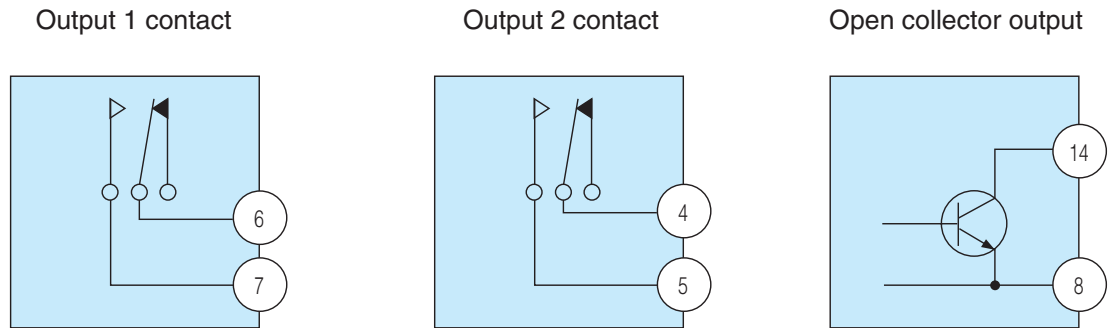

Connecting

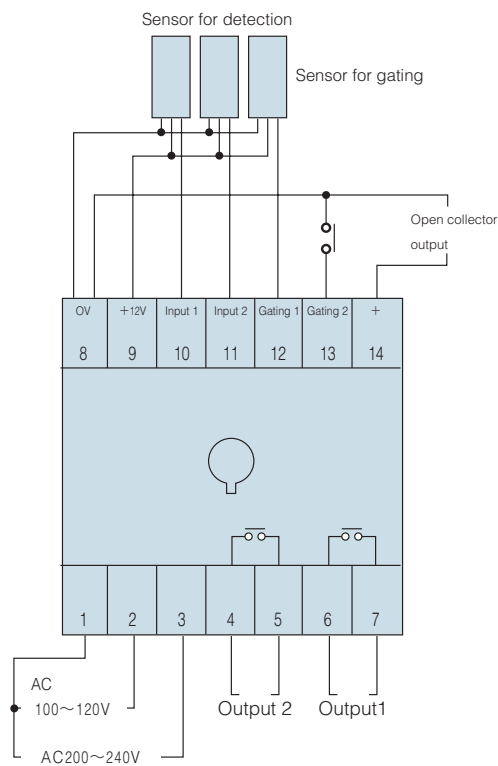

Dimensions (in mm)

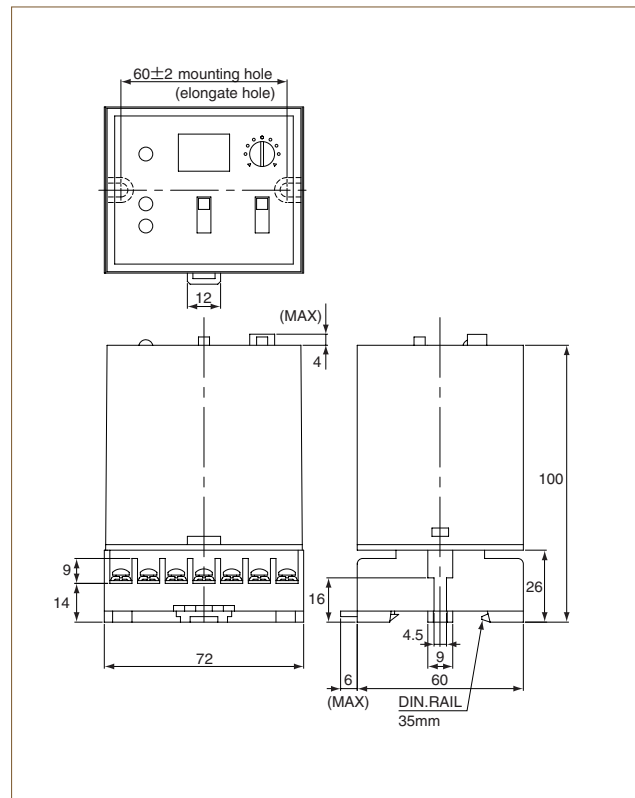

Logic Codes (Digit 1)

Code No.	0	1	2	3	4	5	6	7
Output 1	○	●	○	●	○	●	○	●
Output 2	○	○	●	●	○	○	●	●
Gate	○	○	○	○	●	●	●	●

○ Activated for ON (L) / ● Activated for OFF (H)

The value of the first digit specifies a combination of input active states. ○ means activated for ON (L) and ● activated for OFF (H).

Any unused input must be set at the value marked with ●.

Function Codes (Digit 2) (output operation specified by combination of 3 inputs)

(1) 2-channel

Inputs 1 and 2 are respectively ANDed with gating input and Outputs 1 and 2 are individually activated. This setting makes the unit function as a 2-channel control unit. The timer is provided for Output 1 only.

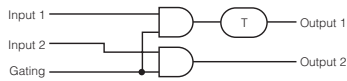

(2) AND

Inputs 1, 2 and gating input compose an AND circuit. Three inputs are ANDed and the signal is output as Output 1.

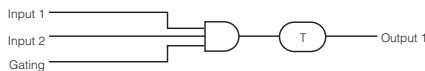

(3) OR

Inputs 1 and 2 are ORed, which is ANDed with gating and the resulting signal is output as Output 1. Photo sensors allow wired ORing, for which all sensors should be connected with one point regardless of Input 1 or 2.

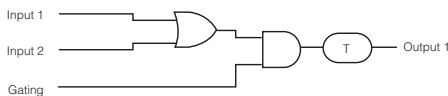

(4) XOR

XOR stands for exclusive OR, which activates output when the states of Inputs 1 and 2 do not agree. When Input 1 is supplied with detection signal and Input 2 with comparator signal and gating signal is input, the comparator functions only when the gate signal is input. Output signal is activated when the signal states do not agree.

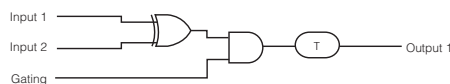

(5) LATCH

May be used for self-holding.

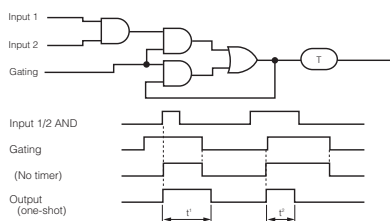

(6) CL.AND

The states of Inputs 1 and 2 are determined at the moment gating signal is input (0.5 ms) for output.

Generally, the output is a one-shot signal and applications usually involve photo sensors as in the detecting the orientation of labels.

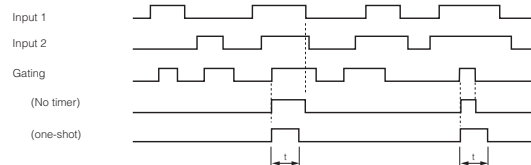
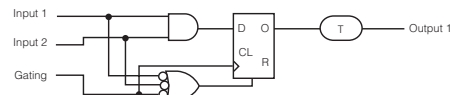

(7) GATE MEMORY

Whether Input 1 or 2 is supplied while gating signal is input is temporarily stored and the stored state is output at the fall of gating signal.

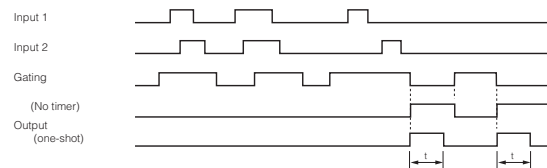
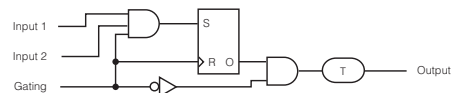

(8) Edge control

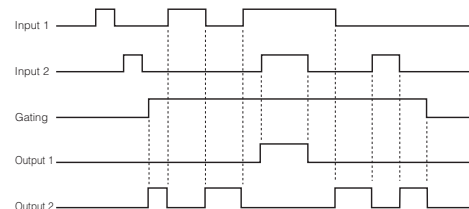
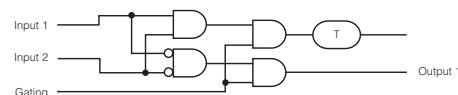

Applications

Work size differentiation

The height of a robot arm with a chuck is controlled according to the height of the work (material) carried on a conveyor. Two sets of through-beam photo sensors are used. The second sensor (bottom) is also used for timing and 2 signals are output.

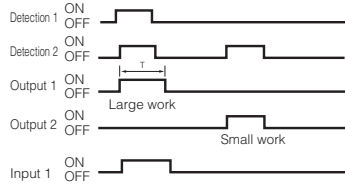

	Operation mode of sensor	Code setting	
		Function code	Logic code
Detection 1	Dark-ON mode	1	2
Detection 2	Dark-ON mode		

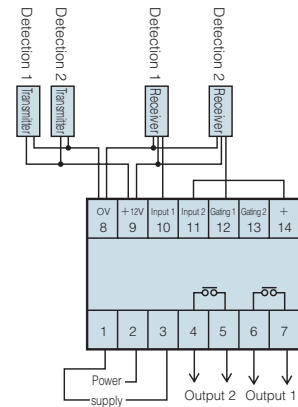
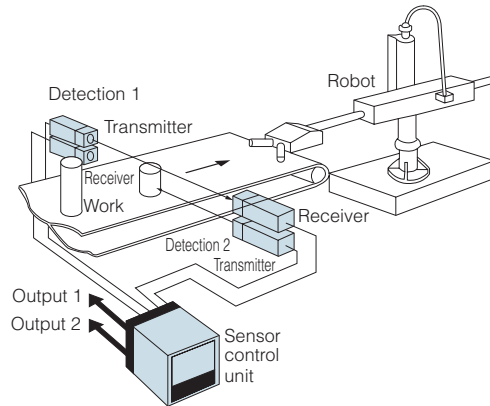

Detection of level of liquid in transparent container

Through-beam photo sensors are used to see if the level of the liquid in transparent containers is as specified. Photo sensors with sensitivity adjustment are suitable for this purpose, which allows sensitivity setting that does not activate the sensors with the container only but activates with the liquid.

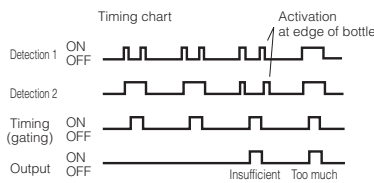

	Operation mode of sensor	Code setting	
		Function code	Logic code
Detection 1	Dark-ON mode	4	1 or 2
Detection 2	Dark-ON mode		
Timing	Light-ON mode		

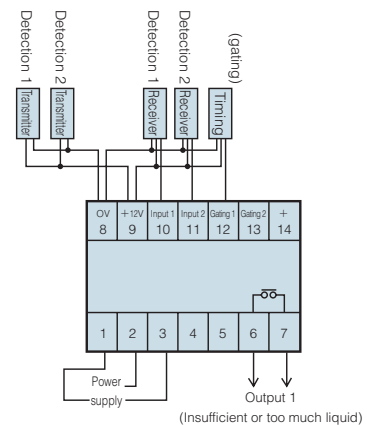
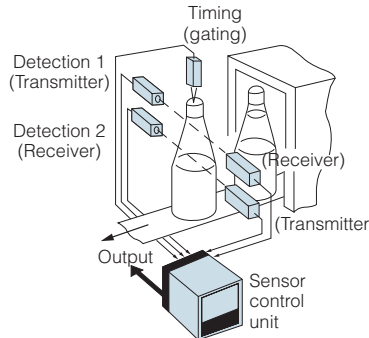

Detection of broken pins of diodes, resistors, etc.

Fiber optic sensors are used to check for any broken pins on both sides of taped electronic components such as diodes and resistors. Components with shorter pins due to breakage or bend are judged as defective.

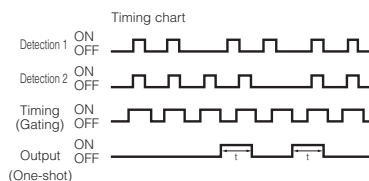

	Operation mode of sensor	Code setting	
		Function code	Logic code
Detection 1	Light-ON mode	7	0
Detection 2	Light-ON mode		
Timing	Light-ON mode		

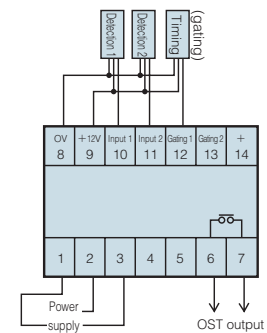
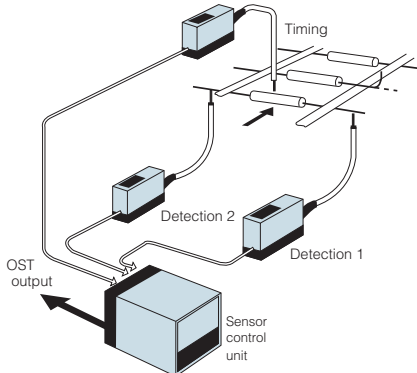

Applications

Detection of marks on transparent glass

A through-beam fiber optic sensor is used to see if manufacturer logos, etc. are printed on transparent glass. A diffuse-reflective type photo sensor that uses reflection from the glass for detection is used for timing. Products for which the fiber optic sensor is never activated during output of the other sensor (logo print missing) are judged as defective.

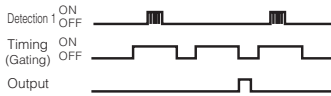

	Operation mode of sensor	Code setting	
		Function code	Logic code
Detection 1	Dark-ON mode	7	2
Timing	Light-ON mode		

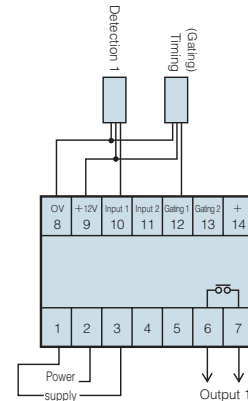
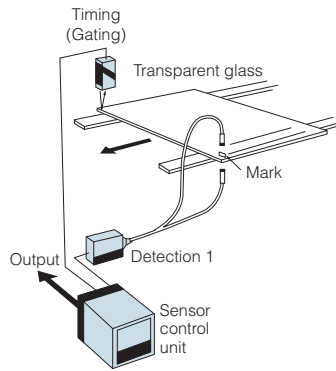

Detection of medical gauze

In the inspection process of sticking plasters, through-beam photo sensors are used for detection of gauze on plastic bandage. For the detection of gauze, a photo sensor with sensitivity adjustment is suitable, which allows sensitivity setting that does not activate the sensor with the plastic bandage only but activates with the gauze and bandage combine.

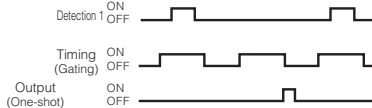

	Operation mode of sensor	Code setting	
		Function code	Logic code
Detection 1	Dark-ON mode	7	2
Timing	Light-ON mode		

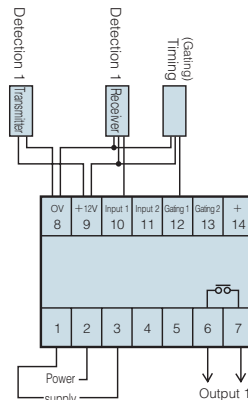
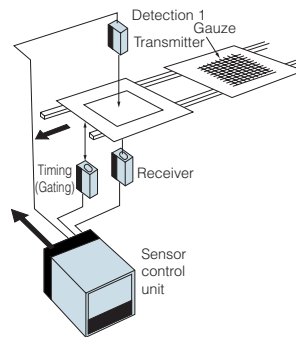

Prevention of double operation on pressing machine

A sensor is used to detect any pressed work (material) remaining without being ejected (sensor beam not blocked) to prevent double pressing, which prevents damage to the die.

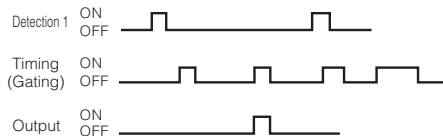

	Operation mode of sensor	Code setting	
		Function code	Logic code
Detection 1	Dark-ON mode	7	6
Timing	Limit switch		

