





• Generic type with LED

- Water resistance to IP 67 standard allows washing together with line equipment. This is achieved by complete resin filling

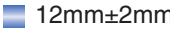

- Ultraviolet luminescence mark sensor
Model: GR12UVS
Ideal for detection of hidden or fluorescent marks

Type

Detection method	Detecting distance	Model	Light source	Operation mode	Output mode
 Limited reflection type	 12mm±2mm	GR12RS	Red LED	Light-ON/Dark-ON selector switch	NPN open collector
		GR12R			
		GR12GS	Green LED		
		GR12G			
	 20~70mm	GR40R	Red LED		
		GR60R			
	 12mm±2mm	GR12UVS	Ultraviolet LED		

Sample Application

Detection of transparent register marks or stickers containing fluorescer
 Marks reliably detected without influence of background color or pattern

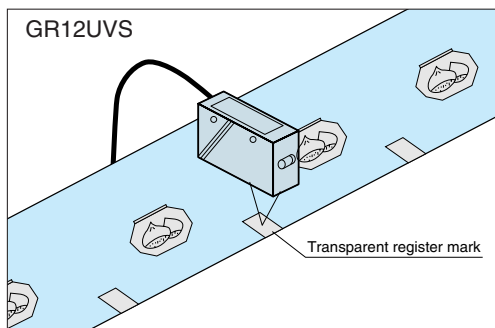

- Mark sensor with detecting distance of 30-120 mm also available
Model: GR100R (PN)

Rating/Performance/Specification

	Type	GR12RS	GR12GS	GR40R	GR60R	GR12UVS
	Side-on Head-on	GR12R	GR12G	_____	_____	_____
Rating/performance	Detection method	Zone-reflective type				
	Detecting distance	12mm ±2mm		20~70mm	20~90mm	12mm ±2mm
	Power source	12 – 24 VDC ±10% Ripple: 10 % max.				
	Current consumption	25 mA max.	30 mA max.	25 mA max.		26 mA max.
	Output mode	NPN open collector output Rating: sink current 100 mV (30 VDC) max.				
	Operation mode	Light-ON/Dark-ON selectable (with switch)				
	Spot diameter	ø1mm		ø1.5mm *1	ø4mm *1	ø0.5mm
	Smallest detectable mark width	1 mm (black mark on white background)	1 mm (red mark on white background)		_____	
	Response time	1 ms max.				
	Specification	Light source (Light wavelength)	Red LED (680nm)	Green LED (568nm)	Red LED (660nm)	
Volume (VR)		4-turn sensitivity adjustment without stopper provided				
Indicator		Light reception indicator (red LED) Stability indicator (green LED)				Light reception indicator (orange LED) Stability indicator (green LED)
Short circuit protection		Provided				
Case material		Polycarbonate (lens of GR12UVS: glass)				
Connection		Permanently attached cord (outer diameter: dia.4.2) 0.3 mm ² x 3cores, 3 m				
Mass		About 100 g max.				
Notes		*1 At detecting distance 40 mm *2 (Note) Do not look straight into the light source while illuminated. The strong UV ray may damage the eye if seen only for a short time. If it is unavoidably necessary to look, be sure to use glasses, etc. with UV protection.				

Environmental Specification

Environment	Ambient light	3,000 lx max
	Ambient temperature	-25 - +55 °C (non-freezing)
	Ambient humidity	35-85%RH (non-condensing)
	Protective structure	IP67
	Vibration	10-55 Hz / 1.5 mm amplitude / 2 hours each in 3 direction

• Applicable power supply unit

PS Series
High capacity of 200 mA at 12 VDC

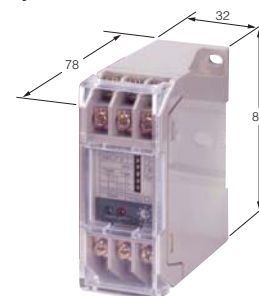

(General-purpose type) PS3N
PS3N-SR
(Multifunctional type) PS3F
PS3F-SR

• Stability indicator and light reception indicator

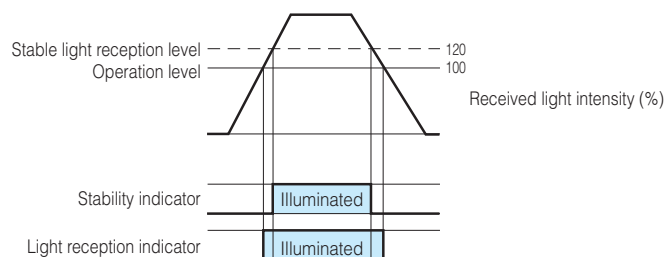

- The stability indicator (green LED) is illuminated when the received light intensity at light reception is well above (120 % of) the output operation level.
- While the stability indicator is illuminated, stable detection is unaffected by change in environment such as ambient temperature.

Input/Output Circuit and Connection

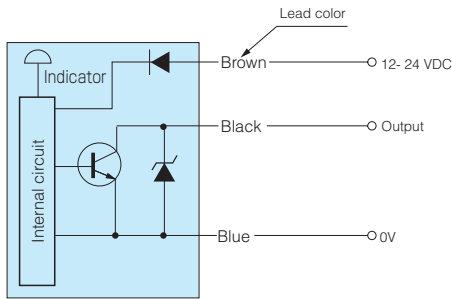

Operation mode switching

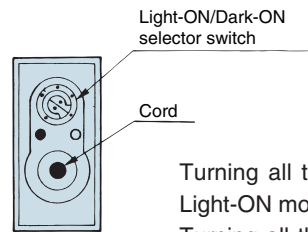

Turning all the way to the left enables the Light-ON mode.
Turning all the way to the right enables the Dark-ON mode.

- The output transistor turns off when load short circuit or overload occurs.
- Check the load and turn the power back on.

Activation Area Characteristics (Typical Example)

GR12RS • GR12R
(50 x 50 White drawing paper)

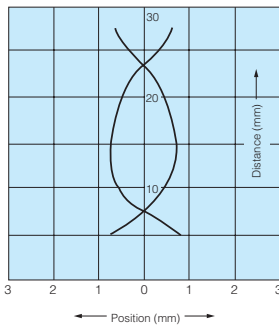

GR12GS • GR12G
(50 x 50 White drawing paper)

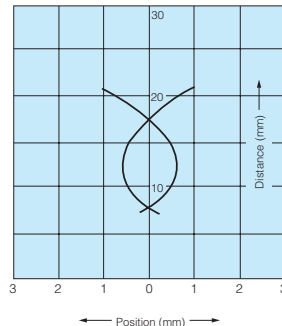

GR40R
(50 x 50 White drawing paper)

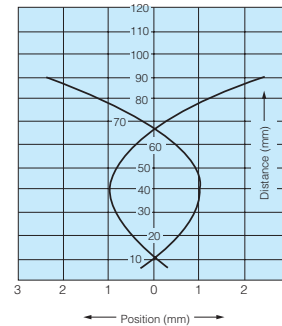

GR60R
(50 x 50 White drawing paper)

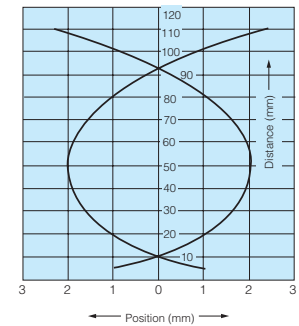

GR12UVS
(50 x 50 White drawing paper)

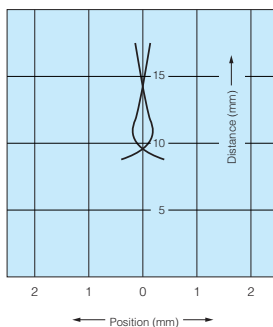

Dimensions (in mm)

Side-on type
GR12RS
GR12GS
GR40R
GR60R

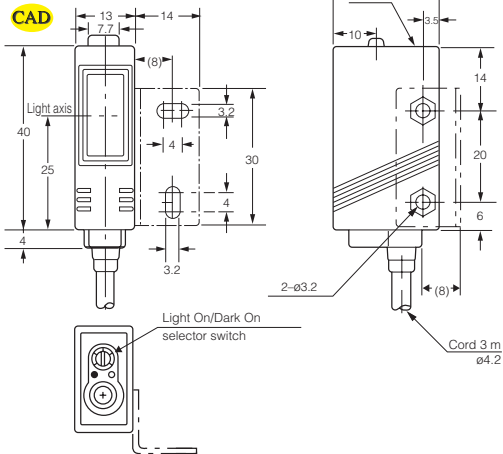

Head-on type
GR12R
GR12G

CAD

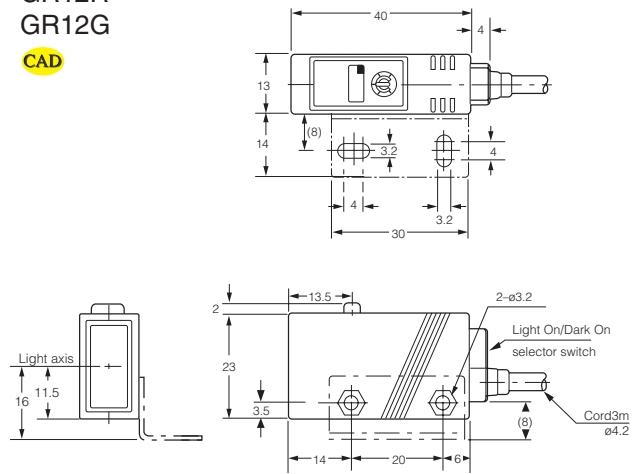

GR12UVS

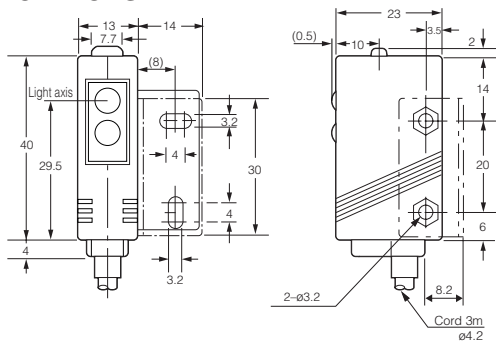

Sensitivity adjustment

The sensitivity adjustment is a 4-turn pot. without stopper. Turning four revolutions clockwise (to LIGHT) enables the maximum sensitivity and turning four revolutions counterclockwise (to DARK) enables the minimum sensitivity. There is no stop on the pot. and it can be turned more than four revolutions. Turning the pot the other way immediately makes the adjustment effective and there is no play in the adjustment.

- Place the detection object at the given position and direct the spot on a region with high reflectance. Turn up the sensitivity adjustment gradually from MIN and find the point at which the light reception indicator (LIGHT) is illuminated (Point A).
- Direct the spot on a region with low reflectance, further turn up the sensitivity adjustment gradually from Point A until the light reception indicator is illuminated. Turn down the adjustment gradually from that point and find the point at which the light reception indicator goes out (Point B).
If the light reception indicator is not illuminated even after turning four revolutions, the point reached after turning four revolutions is regarded as Point B.
- Set the adjustment at midway between Points A and B.

