

- **Ultra-thin**
Slim type of only 13 mm thick and 30 mm wide never affecting work efficiency
- **High-intensity red LED employed**
Large operation indicator of high-intensity LEDs in series offering superb visibility, may double as work instruction indicator
- **Objects as small as ϕ 30 detected**
- **Automatic sensitivity compensation feature**
- **Anti Interference feature**
Allowing adjacent mounting of 2 units for wider range of applications

Type

Detection method	Detecting distance	Light axis interval	No. of light axes	Detecting width	Set model No.	Operation mode	Detecting object
Through-beam type	5m	20mm	8	140mm	ESN-T8	Activated when light beams of all axes are received	Opaque object of ϕ 30 mm min.
			12	220mm	ESN-T12		
			16	300mm	ESN-T16		
			20	380mm	ESN-T20		

*For prices of the transmitter and receiver for separate purchase, see the Price List at the end of this book. Mounting brackets are separately available. See "With Mounting Bracket (Optional) Attached" for details.

Transmitter-receiver linked operation indicator

High-intensity LEDs in series

Wide display offers excellent visibility

Optimum sensitivity maintained by automatic sensitivity compensation feature

Thin and slim size requiring minimum mounting space

Flexible cord orientation (left/right/rear) for routing convenience

Wide display may be used as work instruction indicator

Rating/Performance/Specification

Model	Set model No.	ESN-T8 (PN)	ESN-T12 (PN)	ESN-T16 (PN)	ESN-T20 (PN)
	Transmitter model No.	ESN-TL8	ESN-TL12	ESN-TL16	ESN-TL20
	Receiver model No.	ESN-TR8 (PN)	ESN-TR12 (PN)	ESN-TR16 (PN)	ESN-TR20 (PN)
Detection method	Through-beam type				
Detecting distance	5m max.				
Detection object	Opaque object of ϕ 30mm min.				
Light axis interval	20mm				
No. of light axes	8	12	16	20	
Detecting width	140mm	220mm	300mm	380mm	
Power supply	12-24V DC \pm 10% / Ripple 10% max.				
Current consumption	100mA max.	110mA max.	120mA max.	130mA max.	
Output mode	NPN open collector Rating: sink current 100 mA (30 VDC) max. Models with model Nos. ending with "-PN" have PNP open collector output; source current: 100 mA max.				
Operation mode	Activated when light beams of all axes are received (deactivated when light beam of any axis is blocked)				
Response time	7ms max.				
Light source	Infrared LED (wavelength: 850 nm)				
Light-sensitive element	Photo IC				
Indicator	Transmitter: Power indicator (green LED) / Operation indicator (red LED) Receiver: Stable light reception indicator (green LED) / Operation indicator (red LED)				
Material	Case: ABS / Indicator window: acrylic				
Connection	Permanently attached cord (Outer dimension: dia.4.3) Cord length: 3 m Cord: with five 0.2 mm ² cores, gray (transmitter) or black (receiver) covering				
Mass	160g max.	180g max.	200g max.	220g max.	
Auxiliary functions	Automatic sensitivity compensation, Anti Mutual Sensitivity feature for adjacent installation, output short circuit protection				
Accessory	Operation manual Note: Mounting brackets are separately available.				

Environmental Specification

Environment	Ambient light	10000lx max.
	Ambient temperature	-10 - +55°C (non-freezing)
	Ambient humidity	35-85%RH (non-condensing)
	Vibration	10-55 Hz / 1.5 mm amplitude / 2 hours each in 3 directions
	Protective structure	IP40
	Dielectric withstanding	1000VAC for 1 minute / between entire live part and case
	Insulation resistance	500 VDC, 20 M Ω .

Adjacent or face-to-face installation of two pairs of sensors will not cause interference.

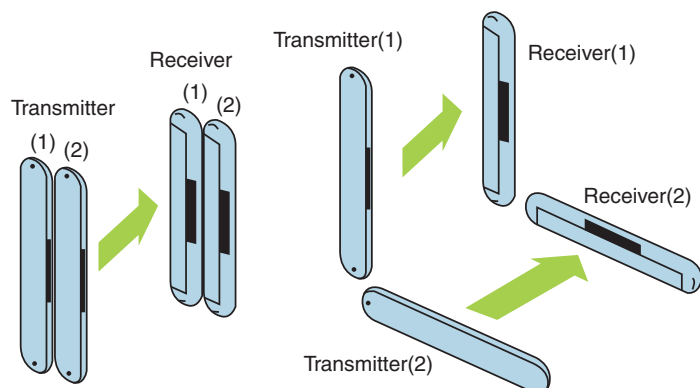

Input/Output Circuit and Connection

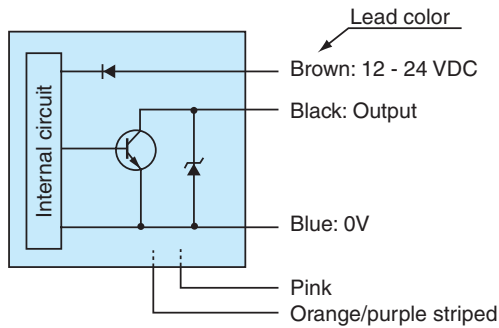

The output is provided with short circuit protection, and turns off when the protection feature is activated. Identify and eliminate the cause of the short circuit and turn the power back on.

Connection for single-set use

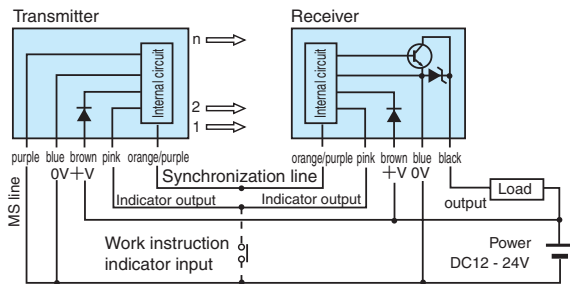

Cord Extension

To extend the cord, use wires of at least 0.5 mm² and limit the length to within 25 m for transmitter and receiver.

Characteristics (Typical Example)

- Parallel displacement characteristics
- Operating angle characteristics
- Smallest detectable object diameter characteristics

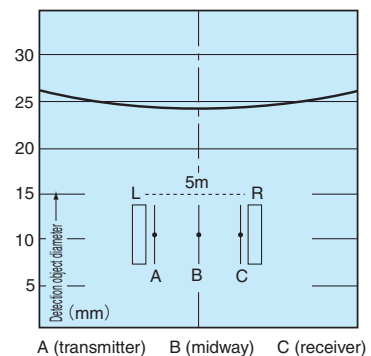
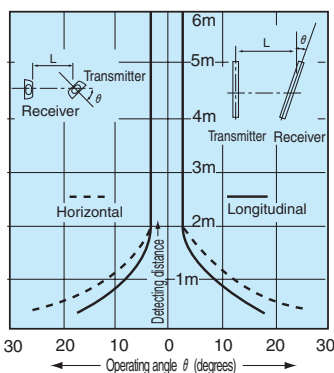
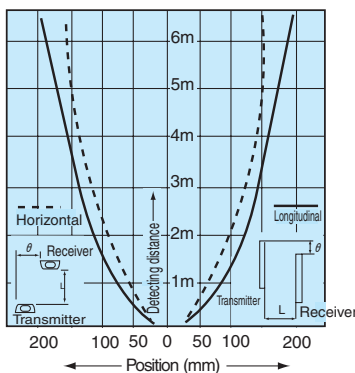

Connection for Anti Interference

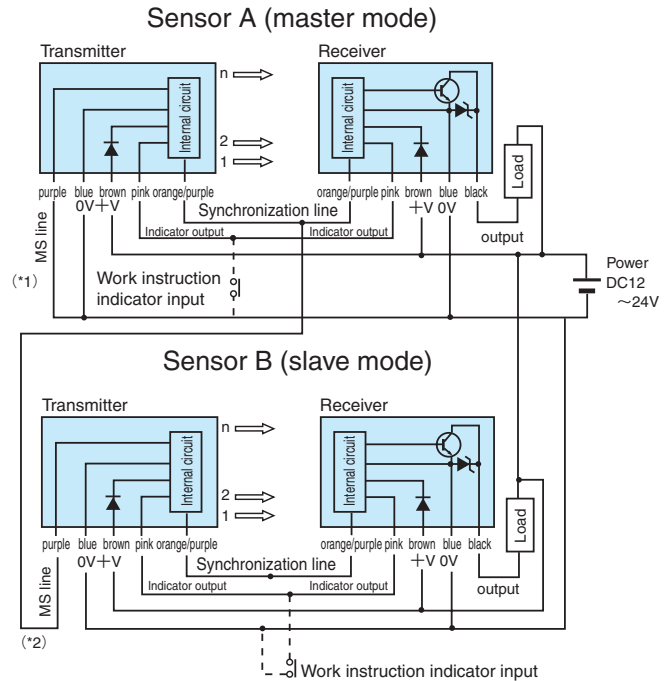

(*1) Connect the MS line (purple) of the transmitter of either (A) of the two sensors to the ground line (blue), which sets the operation mode of this sensor (Sensor A) to master (M mode).

(*2) Connect the MS line (purple) of the transmitter of the other sensor (B) to the synchronization line (orange/purple) of Sensor A, which sets the operation mode of Sensor B to slave (S mode).

(Note 1) When using two sets as a pair, wire so that the operation mode of either of the two will be master and of the other will be slave.

(Note 2) Do not connect the synchronization lines (orange/purple) of Sensors A and B to each other.

For Correct Use



- Be sure to follow the instructions in the operation manual provided for correct use of the product.
- This sensor cannot be used as a press safety device or other safety device for protection of human body that requires conformity to domestic or overseas standards or certification concerning protection of human body. Use for such purposes may lead to death or serious injury in the unlikely event of failure.
- This sensor is intended for detection of ingress of human body or object passing through an arbitrary point not involving protection of human body or safety.
- When using this sensor for safety purposes, ensure safe operation of the system as a whole including detection and control.

Using Operation Indicator as Work Instruction Indicator

Input a flicker signal as a no-voltage contact or NPN transistor open collector input shown as the dotted line in the connection diagram.

The indicator blinks in step with the cycle (both transmitter and receiver flicker). When light beam of any axis is blocked, the operation indicator switches to the illuminated state as the operation indicator.

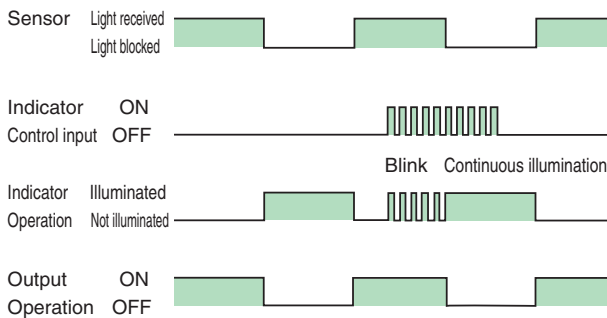

Indicators

Indicator operation

	Name	Color	Description
Transmitter	Power indicator	Green	Illuminated when power is supplied
	Operation indicator	Red	Illuminated when the sensor is activated (light beam of any axis is blocked), turned off when light beams of all axes are received
Receiver	Stable light reception indicator	Green	Illuminated when the received light intensity level is 120% or more of the operation level
	Operation indicator	Red	Illuminated when the sensor is activated (light beam of any axis is blocked), turned off when light beams of all axes are received

Indicator arrangement

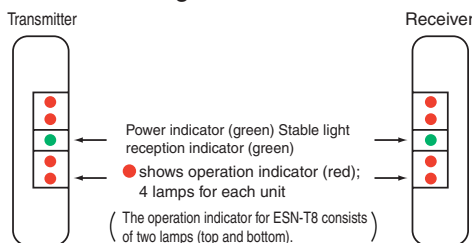

Automatic sensitivity compensation feature

After the light axis alignment is completed, turn the power off once and back on. The automatic sensitivity compensation feature is enabled and the sensitivity is set at the optimum for the sensor.

If the lens is soiled with dirt or dust, the sensitivity is automatically compensated to achieve the optimum sensitivity after the soil is removed.

Sensor Installation Orientation

When installing the sensor, make sure that the ends of the transmitter and receiver with the cord are oriented either upward or downward. The sensor does not function if the transmitter and receiver are not oriented the same way.

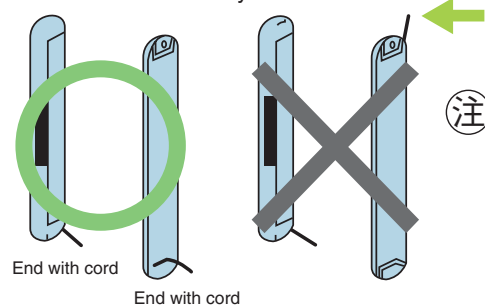

- The tightening torque for installing the sensor (with M4 screws) should not exceed 0.8 N · m.

Installation Location

Any reflecting object (wall, floor, machine, etc.) within the effective range between the transmitter and receiver may allow the light of the sensor to go around the detection object, which is supposed to block the light, and reach the receiver. Choose the installation location carefully (any glossy object such as stainless steel in the surrounding area must be at least 300 mm away from the center of the light transmission and reception area both vertically (up and down) and horizontally (left and right)).

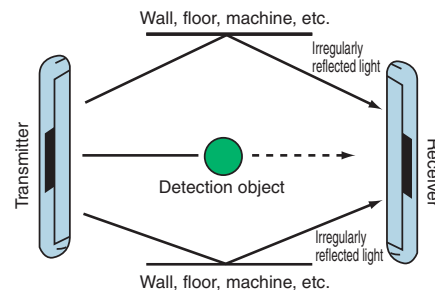

Dimensions (in mm)

CAD

Transmitter

Receiver

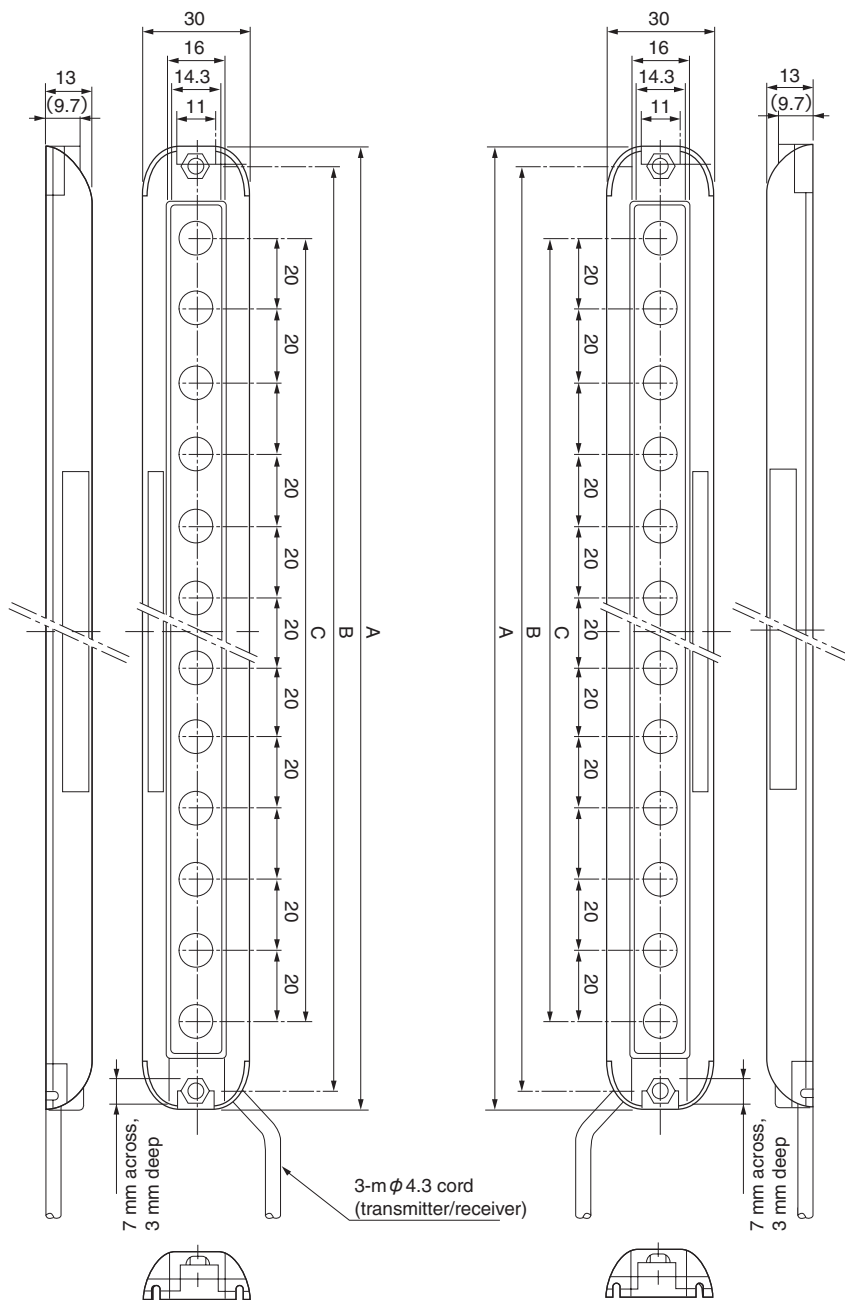

• Dimensions of portions

Model	A	B	C	No. of light axes
ESN-T8	190	180	140	8
ESN-T12	270	260	220	12
ESN-T16	350	340	300	16
ESN-T20	430	420	380	20

