

SpecBright™ LED Spotlights

EXTREMELY BRIGHT LED ILLUMINATION
DESIGNED FOR LONG RANGE APPLICATIONS

FEATURES

- Extremely bright, compact and reliable
- Chip-on-board technology
- Superior uniformity
- Narrow beam emission
- Seamless integration and mounting
- UV, visible and near-IR

APPLICATIONS

- Night vision
- Machine vision
- Covert illumination
- Security ID

ACCESSORIES

- Power supplies
- Current mode drivers
- Heat sinks
- Strobe drivers



StockerYale SpecBright™ LED Spotlights offer several times the brightness, for modules of comparable size. Moreover, the units have a small footprint thus ideal for space constrained applications.

StockerYale's unique series of LED spotlights use high density die level LEDs to produce a bright, highly uniform beam. With a total divergence angle of only 12 degrees, this narrow beam spotlight is suited well for many long range applications.

The illuminators are available in a wide range of wavelengths and are optically efficient, providing more light where you need it. They can be operated in continuous (CW) or pulsed mode and provide the high-power illumination required in machine vision, night vision, covert illumination, and security ID applications.

Custom-engineered LED solutions are also available to meet specific mechanical or optical requirements.

SPECTRAL CHARACTERISTICS¹

Color	Blue	Red	IR	IR
Peak wavelength (nm)	470 ± 10	630 ± 10	740 ± 10	870 ± 10
Spectral width FWHM (nm)	30	30	30	30

ILLUMINATION CHARACTERISTICS^{2,3,4}

Nominal beam cone angle (FWHM): 12 degrees				
illumination diameter FWHM at working distance of 50 mm (mm)	10	10	10	10
Typical irradiance at 50 mm (W/m ²)	650	1,000	200	425
Typical illuminance at 50 mm (lux)	40,000	180,000	NA	NA
illumination diameter FWHM at working distance of 200 mm (mm)	40	40	40	40
Typical irradiance at 200 mm (W/m ²)	125	200	50	100
Typical illuminance at 200 mm (lux)	7,500	35,000	NA	NA

ELECTRICAL CHARACTERISTICS, LIFETIME & ENVIRONMENT^{5,6}

Current mode (code "I")				
Maximum operating current (mA)	400	400	400	400
Mean time before failure (MTBF)	100,000	100,000	100,000	100,000

1 395 nm also available. Please contact us for more details.

2 See Figures 2 and 3 for graphs of FWHM illumination diameter and irradiance, as a function of working distance.

3 Beam divergence is measured with a rotation stage and a photo-detector at a distance where the beam is much larger than the detector aperture. It varies slightly as a function of the wavelength, due to the change in the refractive index of the lens material.

4 Irradiance and illuminance are measured at the center of the illumination field using a 4 mm diameter detector.

5 This product is not 24 V compatible and can only be operated in current mode.

6 Case temperature should not exceed 45°C. Please consult StockerYale for details on lifetime measurements.

ILLUMINATION CHARACTERISTICS

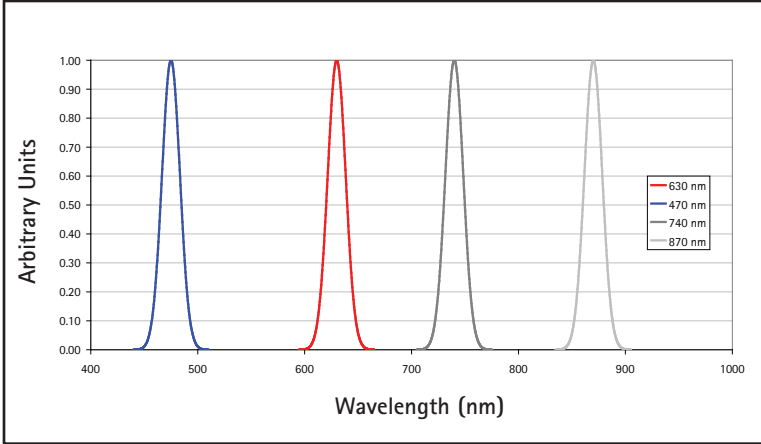

Figure 1 - Spectrum of available wavelengths for our LED spotlight series.



Figure 2 - Diameter of field of illumination vs. working distance for all wavelengths.



Figure 3 - Irradiance vs. working distance for SF1-870.

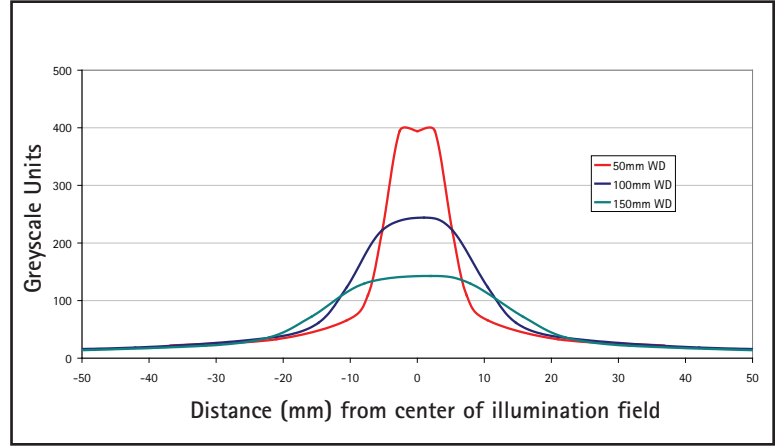

Figure 4 - Intensity profile for SF1-870. Working distances (WD) of 50, 100, and 150 mm.

PRODUCT PART NUMBERS

Product Code	Frontlight	Series	-	Wavelength	-	Current Source	Without or with Heat Sink	Flying Leads	Cable Length (in cm)
S	F	1		470		I	X or H	F	100
				630					(standard)
				740					
				870					

Example: SF1-870-IXF100. Refer to website for complete part number matrix. Please contact us for other wavelengths.

FLYING LEADS

- Flying leads are standard for current source (I) modules.

POWER SUPPLIES

- Current mode driver and power supply to remotely or manually adjust intensity. *Please visit our website for specifications and ordering information.*

STROBE DRIVERS

Due to the thermally optimized design, peak optical powers up to 50 times the CW optical power can be obtained using pulsing. Contact us for more details.

HEAT SINKS

For best operation, the housing temperature should not exceed 45°C. StockerYale provides optimized heat sinks for use with our LED spotlights. *Please visit our website for dimensional diagrams.*

DIMENSIONAL DIAGRAMS

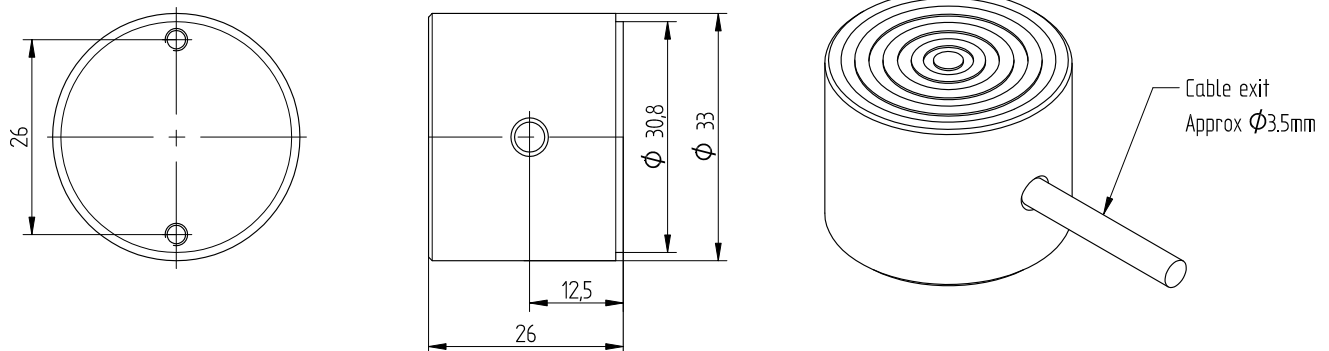

All dimensions in [mm]

Information and specifications contained herein are deemed to be reliable and accurate. StockerYale reserves the right to change these specifications at any time without notice.

