

ILLUMINATION

High Power LED Spot Projectors

POWERFUL LED PROJECTORS FOR
INDUSTRIAL & BIOMEDICAL APPLICATIONS

FEATURES

- Powerful three-chip LED source
- Compact in design
- External potentiometer to control light intensity
- Fan and heat sink for efficient heat dissipation
- Simplified mounting
- White, red, amber, green, and blue

APPLICATIONS

- Machine vision
- Microscopy
- Biomedical



StockerYale High Power LED Spot Projectors are high-intensity LED spotlights that are designed to replace conventional halogen point-sources as well as fiber optic illumination solutions. Compact and lightweight in design, these illuminators are equipped with a separate electronics box which includes an ON/OFF switch and potentiometer to control light intensity.

The high-luminosity LED spot projectors are well suited for both industrial and scientific applications where high-output area illumination is required. They offer long lifetimes and low power consumption when compared to traditional light sources. Due to the module's high-intensity output, the unit includes a fan and heat sink for efficient heat dissipation.

The illuminators are available in a wide range of wavelengths including red, blue, green, amber, and broadband white. These products offer powerful LED illumination required in many machine vision, microscopy, and biomedical applications.

Custom-engineered LED solutions are also available to meet specific mechanical or optical requirements.

SPECTRAL CHARACTERISTICS

Color	Blue	Green	Amber	Red	White
¹ Peak wavelength (nm) / color temp.	455 ± 10	530 ± 15	590 ± 10	630 ± 10	5500 K
Spectral width FWHM (nm)	40	40	40	40	NA

¹Other wavelengths available.

ILLUMINATION CHARACTERISTICS**SERIES 1 – Narrow beam – Divergence angle (FWHM): 10 degrees**

Diameter (FWHM) of field of illumination at 100 mm (mm)	35	35	35	35	35
Typical irradiance at 100 mm (W/m ²)	1,350	240	240	695	NA
Typical illuminance at 100 mm (lux)	45,000	140,000	125,000	125,000	140,000

SERIES 2 – Wide beam – Divergence angle (FWHM): 20 degrees

Diameter (FWHM) of field of illumination at 100 mm (mm)	45	45	45	45	45
Typical irradiance at 100 mm (W/m ²)	900	145	145	415	NA
Typical illuminance at 100 mm (lux)	30,000	85,000	75,000	75,000	85,000

*Irradiance and illuminance are measured at the center of the illumination field using a 4 mm diameter detector.

ELECTRICAL CHARACTERISTICS & LIFETIME

Input voltage (V)	12-32	12-32	12-32	12-32	12-32
Output current (mA)	1,000	1,000	1,000	1,000	1,000
Lifetime (hours)	50,000	50,000	50,000	50,000	50,000

ILLUMINATION CHARACTERISTICS

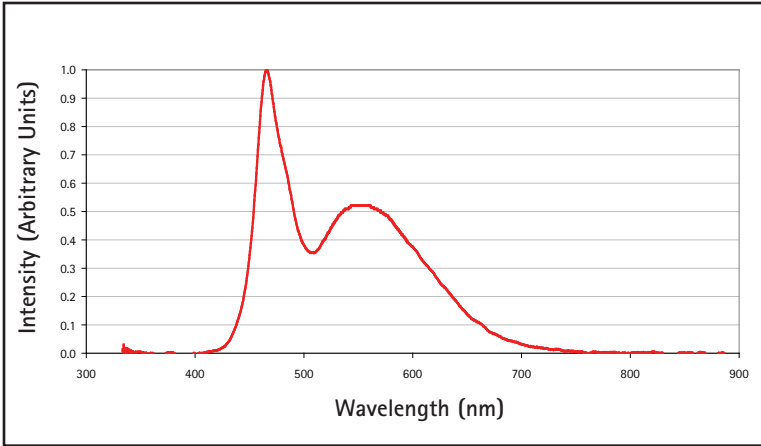

Figure 1 - Typical spectral distribution of a white LED projector.

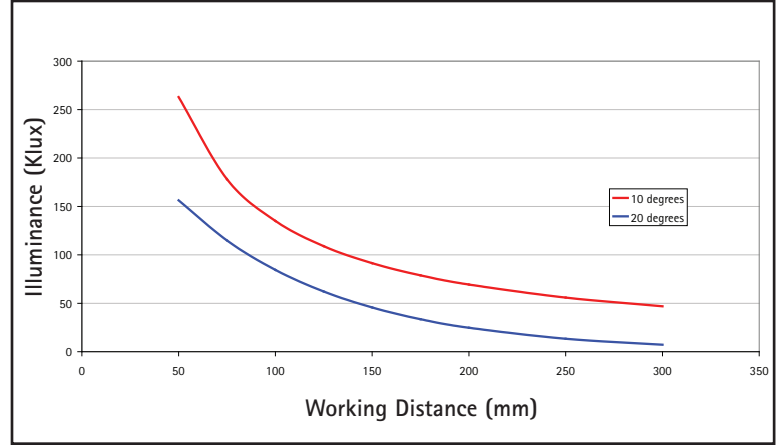

Figure 2 - Illuminance vs. working distance for a white LED projector.

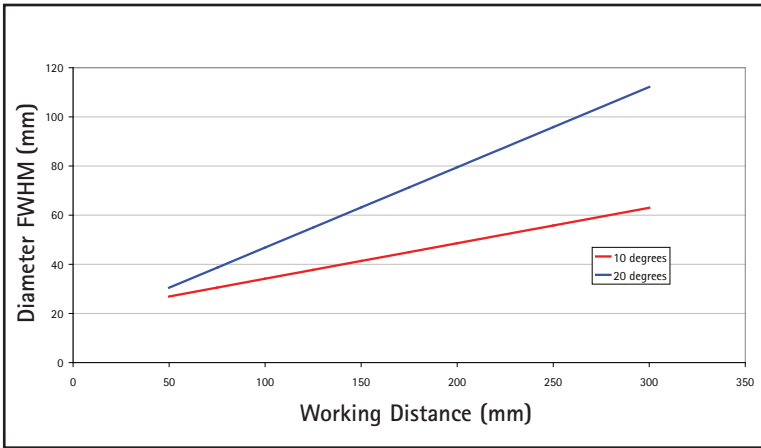

Figure 3 - Illumination diameter FWHM vs. working distance for a white LED projector.

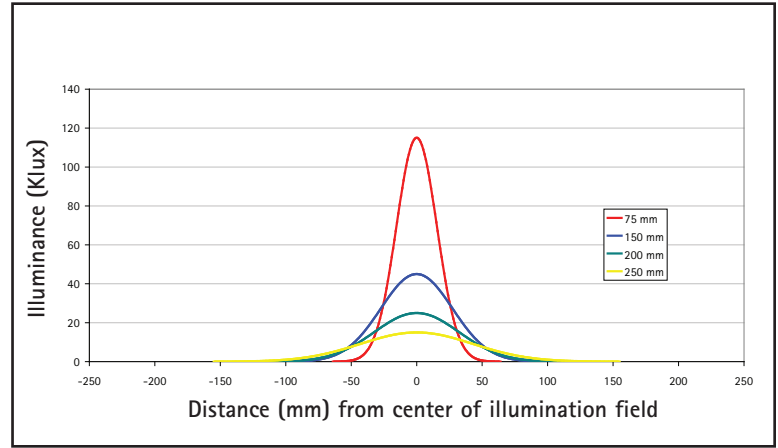

Figure 4 - Intensity profiles for a white LED projector with 20 degree divergence angle. Working distances of 75, 150, 200, and 250 mm.

PRODUCT PART NUMBERS

Product Code	Divergence Angles (10° or 20°)	Standard Spot/Projector	Wavelength (nm)	-	Driver Configuration	Flying Leads or Connector	Cable Length (in cm)
HP	1 or 2	P	455 530 590 630 000 (white)		M	F or C	60 (standard)

Example: HP1P000-MF60. Refer to website for complete part number matrix.
Please contact us for other wavelengths. Power supplies and other accessories sold separately.

FLYING LEADS / CONNECTORS

- Flying leads (standard)
- Connector type: 3 mm mono jack connector

DRIVER CONFIGURATION

- M - Manual intensity control. The projectors are equipped with a separate electronics box which includes an ON/OFF switch and potentiometer to control light intensity.

POWER SUPPLY

- Accepts 12-32 VDC. Consult factory for power supply accessories.

DIMENSIONAL DIAGRAMS

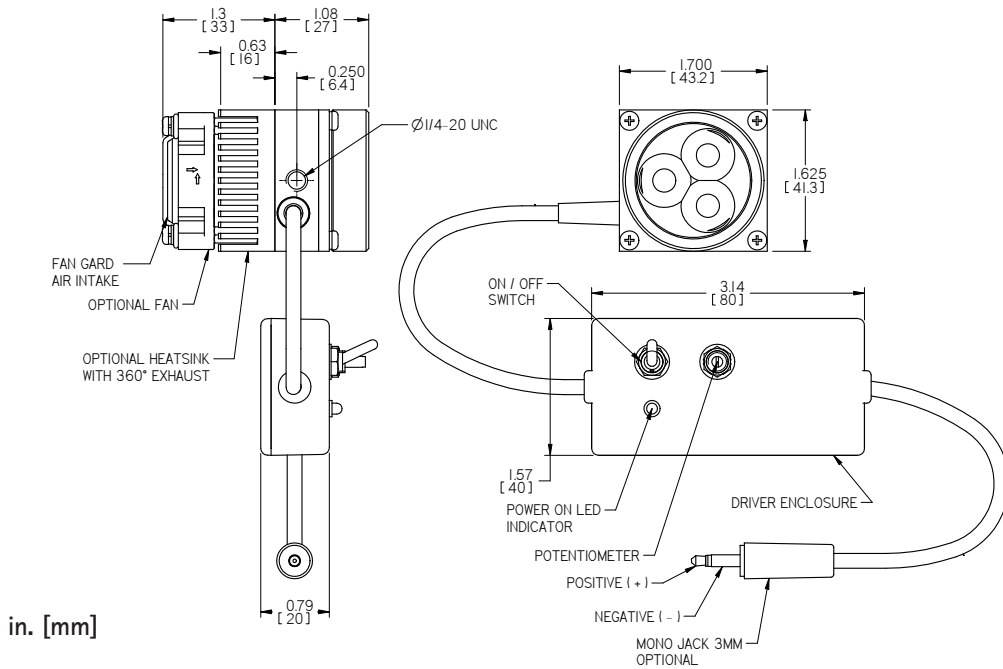

Information and specifications contained herein are deemed to be reliable and accurate. StockerYale reserves the right to change these specifications at any time without notice.

