



Darkfield ringlight, P/N 400 300 with adapter P/N 400 500



Transmitted darkfield light stage, P/N 400 350

# VisiLED Darkfield Lighthoods

*Illumination system specially developed for stereo microscopy and macroscopy applications*

## Lighthoods for darkfield illumination techniques:

- 1 Darkfield ringlight for real incident darkfield
- 1 Transmitted light stage for transmitted darkfield

## Features

- Easily adaptable to microscope objectives by means of thumb screw and adapter rings
- Homogenous illumination
- Best white quality: typically 6,000 K
- Long operating life: typically 10,000 h by actively controlling the LED chip temperature
- Segments controllable in different preset modes for optimum contrasting:

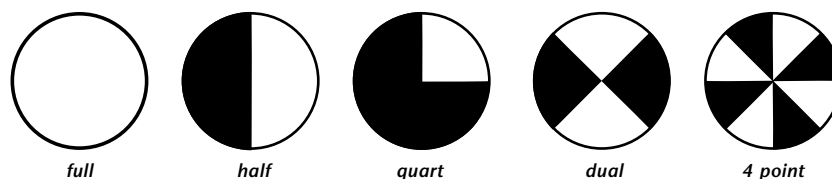

Ringlights and Accessories						
Description	Part No.	Working Distance (WD)	Light flux	Max. Illuminance	Inner Ø	Outer Ø
LED Darkfield ringlight "S40-10D"	400 300	5-15 mm (0.20"-0.59")	50 lm	60 klx (10 mm) (0.39")	66 mm (2.60")	118 mm (4.65")
Transmitted darkfield light stage	400 350	N/A	46 lm	8000 cd/m2 (luminance in center)	active 50 mm (1.97")	84 mm (3.31")

Accessories VisiLED Darkfield Lighthoods	
Description	Part. No.
Combi-Kit to combine one brightfield and the darkfield incident ringlight for mixed illumination techniques	400 500
IL/DL adapter for Ø <sub>i</sub> = 66 mm and Ø <sub>i</sub> = 70 mm fits the incident darkfield ringlight onto LEICA microscopes with PlanApo 2x objective	400 510

For all other microscopes in addition to 400 510 one of the following listed adapters is necessary:					
Ø 58 mm			Ø 66 mm		
Microscope objective	Part. No.	Magnification	Microscope objective	Part. No.	Magnification
ZEISS Achromat S	157 550	1.0 x	LEICA Planachromat M3Z	157 560	1.0 x
ZEISS Achromat S	157 549	1.6 x	LEICA Planapo M3C, MZ8	157 561	1.0 x
ZEISS Achromat S	157 551	2.5 x	LEICA Plan M3Z, MZ8	157 562	1.0 x
ZEISS Duo DS	157 550	1.0 x	LEICA Planapo M10, MZ12, MZ APO	157 562	1.0 x
ZEISS Plan S	157 550	1.0 x	LEICA Planapo M10, MZ12, MZ APO	No adapter required	1.6 x
ZEISS Planapo	157 555	1.0 x	LEICA Planapo M3C, MZ8	No adapter required	1.6 x
ZEISS Planapo	157 564	1.6 x	LEICA Planachromat M3Z, MZ8	No adapter required	1.6 x
LEICA Achromat M3	157 552	1.0 x	LEICA GZ6	157 563	---
LEICA Achromat M3	157 552	1.5 x			
LEICA Achromat M3	157 553	2.0 x			
LEICA Achromat GZ6	157 554	2.0 x			

- Manufactured in the EU.

# VisiLED Darkfield Lighthheads

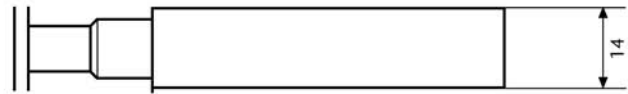
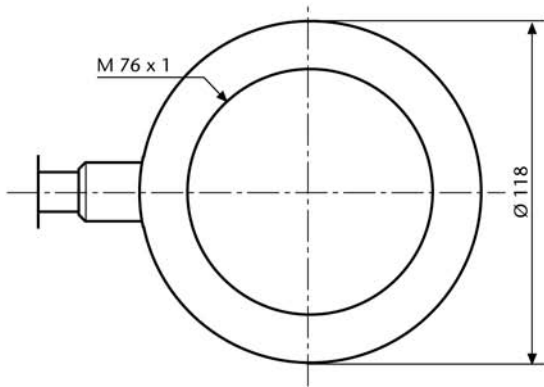

Darkfield ringlight, P/N 400 300

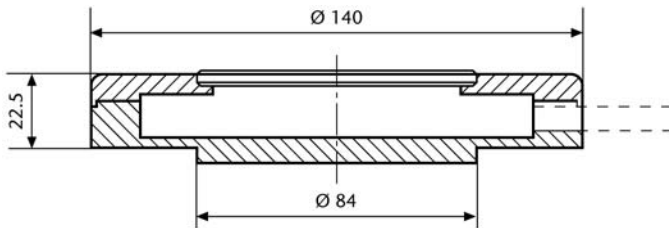

Transmitted darkfield light stage, P/N 400 350

Part. No.	Microscope	Insert diameter in microscope stand
400 350	Standard/Zeiss	Ø 84 mm
400 355	Olympus	Ø 100 mm
400 360	LEICA	Ø 120 mm