

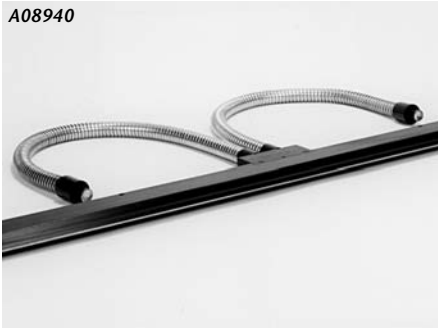

A08940



Continuous Lightline, A08940

A08964

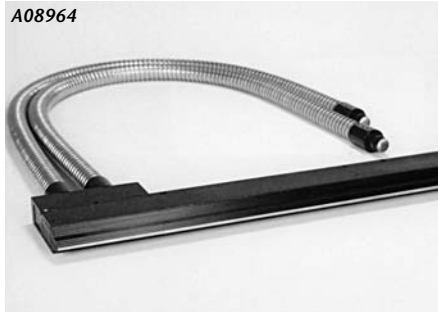

Continuous Lightline, A08964

Spatially Randomized Lightlines

A patented exclusive! 24" and 40" lines of white light for web and line scanning applications.

Features

- Manufactured using a patented process called spatial randomization. The process allows light from each input to be distributed over the entire length of the line. Therefore, should a light source fail while using multiple inputs, intensity is evenly reduced over the length of the line, rather than losing all light in a section of the line.
- Calibrated to ± 15 gray scale levels at a mean of 200 with a gamma setting of 1.0 to deliver optimum uniformity. Calibration specifications and line scans are available upon request. (See example)
- Assembly method accurately positions the fiber line within the body on all three planes, to a tolerance of $\pm .004"$ (.1)*. The technique assures the fiber axis will be parallel with the mounting surface of the body.
- Standard input ferrule fits ColdVision Series light sources. Can also be used with strobes.
- The 24" (610) lightline accepts our dichroic filters and diffusers. To use color filters on the 40" (1016) line, part number A08931, color filter adapter, is required.
- Rugged aluminum body with a black anodized finish.
- Stainless steel tubing protects the fiber bundle.
- Custom lengths, bundle exits, and line widths can be designed for your unique requirements.
- Lead-time may be required when ordering continuous lightlines and/or any custom configuration of these products.
- Cylindrical lenses are available. They are designed to collect light exiting the lightline to increase intensity up to a factor of 10.
- Manufactured in the USA.

LIGHTLINES

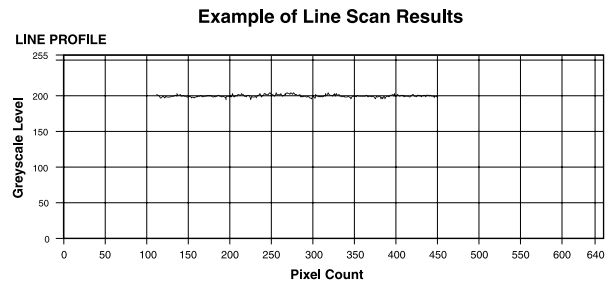
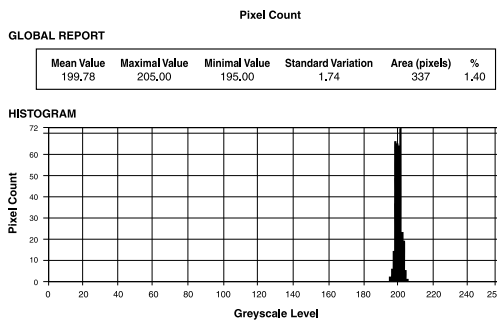

Lightlines and Lenses						
Part No.	Line Dimensions	Input Active Fiber Dia.	Gray Scale Uniformity	Bundle Length	Part No. for Lens	
	Length x Width				Cylindrical	Apertured
A08940	40"x.015" (1016x.38)	.62" (16)*	± 15	30" (762)	A08860	Custom
A08964	24"x.022" (610x.56)	.57" (14)	± 15	40" (1016)	A08864	Custom

Spatially Randomized Lightlines

Dimensions in () are in mm

Input: Black Anodized Aluminum

Body: Black Anodized Aluminum

Sheathing: Stainless Steel Covered Metal Tubing

Warning: This product is manufactured with glass fiber. Not for use in cable/hose carrier. Call SCHOTT to discuss moving cable/hose carrier applications.

A08940
40" (1016) Lightline

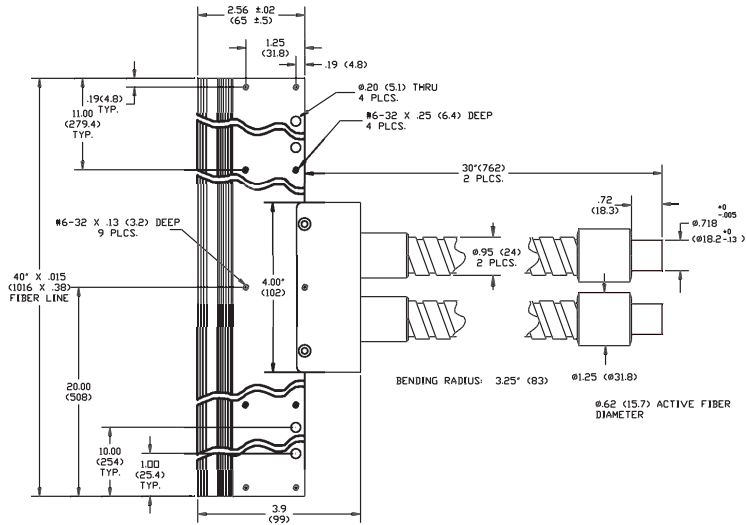

A08964
24" (610) Lightline

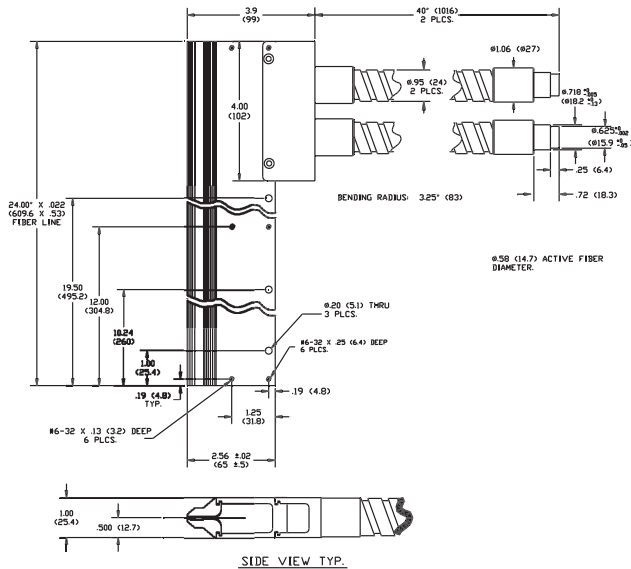

TECHNICAL SPECIFICATIONS