

## The iPORT™ FB1000-ST Protocol Engine

### A superior-performance OEM board that reliably drives data in real time over fiber-based Gigabit Ethernet connections

Pleora's iPORT FB1000-ST Protocol Engine is a fast, economical way to add high-performance, fiber-based Gigabit Ethernet (GigE) connectivity to almost any product. The engine is ideal for manufacturers that want to transport data in real time over GigE, but need to meet regulatory requirements for fiber transmission, and/or achieve the long-distance reach and superior noise immunity of optical connections.

Applications for the board include performance-oriented systems for medical imaging, industrial inspection, high-end security/surveillance, traffic imaging, and post and parcel sorting.

The FB1000-ST grabs almost any type of digital data – including imaging data, video, and voice – converts it to IP quickly and efficiently, and sends it to PCs over optical GigE links or LANs. Data is streamed continuously with low, predictable latency (delay) at the full, 1-Gb/s data rate using the same field-proven technology and protocols featured in Pleora's PT1000 series of iPORT IP Engines.

The engine is a compact, low-power board designed specifically for OEM use. It integrates easily with a wide range of system architectures. The standard SFP (small form-factor pluggable) fiber connector on the engine interfaces directly to fiber cable via standard SFP transceivers. It supports most fiber types and distance requirements.

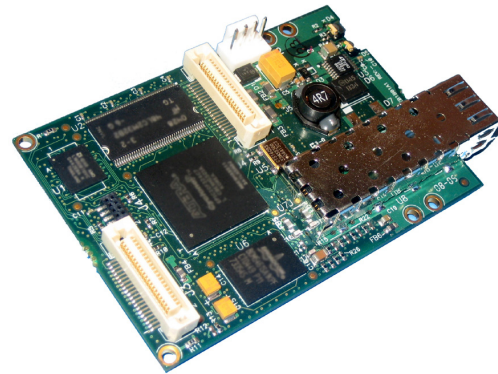

The FB1000-ST also includes an advanced Programmable Logic Controller that allows users to precisely measure and control the operation of conveyors, encoders, cameras, and other system elements – either independently from or in conjunction with the host PC on the network.

At the PC, data is driven directly to user memory by Pleora's powerful iPORT IP Device Driver. Shipped with the engine, this driver runs on standard GigE Cat-5 and fiber NICs (network interface card/chips), eliminating the need for frame grabbers. It uses almost no CPU, leaving most of the PC's processing resources available to run applications.

Also shipped with the engine is Pleora's iPORT Software Development Kit (SDK), which gives users the building blocks needed to quickly and easily interface to just about any custom application or third-party applications package.

Together, the FB1000-ST engine, the driver, and the SDK form a seamless end-to-end iPORT Connectivity Solution that transfers data cost-effectively, and with unmatched performance, over fiber-based GigE links.

## The iPORT FB1000-ST Protocol Engine

Data Acquisition Features	
Accepts LVCMOS/LVTTL signals	<ul style="list-style-type: none"> <li>Compatible with most 3.3-Volt chips</li> </ul>
Integrated acquisition engine	<ul style="list-style-type: none"> <li>Different FPGA loads available to allow users to acquire data from a variety of sources, including raw digital data streams, de-serialized Camera Link™, and CMOS image sensors. Custom FPGA loads are routinely available</li> <li>Supports data depths of up to 24 bits at up to 80 MHz. Multiple 8, 10, or 12-bit data streams can be acquired simultaneously</li> </ul>
Free running or externally triggered	<ul style="list-style-type: none"> <li>Flexible acquisition modes</li> </ul>

Programmable Logic Controller Features	
4 Inputs (LVCMOS/LVTTL) 7 Outputs (LVCMOS/LVTTL)	<ul style="list-style-type: none"> <li>Provides a flexible, general-purpose interface</li> <li>Allows synchronization of multiple devices or equipment</li> <li>Flexible triggering capabilities, including Boolean combinations, Camera Link control signals, encoders, and timestamps</li> <li>Built-in debouncers</li> </ul>
4 programmable pulse generators	<ul style="list-style-type: none"> <li>Flexible trigger control that can be attached to any input or output or to internal signals</li> </ul>
2 UART serial links (LVCMOS/LVTTL)	<ul style="list-style-type: none"> <li>Serial control of camera and other devices over the Ethernet link</li> </ul>
Delayer, rescaler, and general-purpose counter	<ul style="list-style-type: none"> <li>Allows full synchronization of line scan cameras</li> <li>Allows synchronized capture between multiple cameras</li> <li>Allows camera acquisition to track changing speeds on conveyor belts</li> </ul>
Timestamp trigger, counter, and reset	<ul style="list-style-type: none"> <li>Allows system actions to be triggered based on timestamps</li> <li>Allows resets to be broadcast from host computer to all iPORT IP engines in system</li> </ul>
Host interrupts	<ul style="list-style-type: none"> <li>Allows host to be interrupted based on events on any input or internal signal</li> </ul>

Characteristics	
Dimensions	<ul style="list-style-type: none"> <li>8.8 cm x 5.6 cm x 1.2 cm (L x W x D)</li> </ul>
Operating temperature	<ul style="list-style-type: none"> <li>0°C - 70°C</li> </ul>
Power supply	<ul style="list-style-type: none"> <li>4.5 V - 16 V</li> </ul>
Power consumption	<ul style="list-style-type: none"> <li>2.4 W</li> </ul>
Certification	<ul style="list-style-type: none"> <li>FCC</li> </ul>

Connectors	
Power	<ul style="list-style-type: none"> <li>Molex 4-pin 6373 series (22-23-2041)</li> </ul>
Network	<ul style="list-style-type: none"> <li>SFP fiber connector with EMI cage (SFP transceiver not included)</li> </ul>
I/O Interface	<ul style="list-style-type: none"> <li>2 x Hirose FX6-40S-0.8SV2</li> </ul>

## Pleora's iPORT Connectivity Solution

Network Interface	
Fiber-based Gigabit Ethernet	<ul style="list-style-type: none"> <li>• Easy-to-implement</li> <li>• Optical fiber-based for very long reach using standard equipment</li> </ul>
802.3, Ethernet v2.0, IP, ICMP, UDP and PING	<ul style="list-style-type: none"> <li>• Works with standard, off-the-shelf Ethernet switches and networks</li> </ul>
ARP and BOOTP capability	<ul style="list-style-type: none"> <li>• In addition to static IP support, dynamically discovers and obtains IP addresses for all devices on network</li> </ul>
iPORT Multimedia Streaming Protocol	<ul style="list-style-type: none"> <li>• Guarantees efficient delivery of all packets</li> <li>• Delivers comprehensive data transfer diagnostics</li> </ul>
Multicast capability	<ul style="list-style-type: none"> <li>• Enables advanced distributed processing and control architectures</li> </ul>
SFP fiber connector	<ul style="list-style-type: none"> <li>• Direct connection to SFP terminated fiber. SFP transceivers recommended and supported by Pleora include Sumitomo SCP6856-GL-CTH and SCP6584-GL-CTH, Formica Optocom SFP-0850-M3511-111G, and Agilent HFBR-5710L. Other transceivers can be supported. Contact Pleora for details.</li> </ul>
iPORT Protocol Engine	
FPGA-based; no embedded O/S or software	<ul style="list-style-type: none"> <li>• Highly reliable, fast data transfer with low, predictable end-to-end latency</li> <li>• Wire-speed performance</li> <li>• Field-upgradeable via IP/Ethernet link</li> <li>• Supports custom processing</li> </ul>
On-board 16-MB frame buffer	<ul style="list-style-type: none"> <li>• Zero packet loss</li> <li>• Images can be recorded by the engine and played back on the host PC</li> <li>• Can be expanded to 64 MB. Some conditions apply. Contact Pleora for details.</li> </ul>
Integrated windowing, frame skipping, sub-sampling and inter-packet delay	<ul style="list-style-type: none"> <li>• On-demand bandwidth control and region-of-interest management</li> </ul>
User-definable pixel packing	<ul style="list-style-type: none"> <li>• Supports packed or unpacked data formats, as per application requirements</li> </ul>
LED display	<ul style="list-style-type: none"> <li>• Indicator for power, status, network availability, and bandwidth</li> </ul>
iPORT High-Performance IP Device Driver	
Compatible with all Intel PRO/1000 NICs (network interface cards/chips)	<ul style="list-style-type: none"> <li>• Range of network cards supporting all PCI, PCI-X, and PCI-Express variants</li> </ul>
More than 800 Mb/s payload data transfer	<ul style="list-style-type: none"> <li>• High-performance streaming for even the most demanding applications</li> </ul>
DMA transfer with low CPU usage	<ul style="list-style-type: none"> <li>• CPU available for PC-based processing tasks</li> </ul>
Full Windows stack bypass	<ul style="list-style-type: none"> <li>• CPU-efficient stack processing, enabling simultaneous, real-time applications processing</li> </ul>
Jumbo frame support to 16 KB	<ul style="list-style-type: none"> <li>• Highest transfer efficiency on networks supporting jumbo frames</li> </ul>
iPORT Universal IP Filter Driver	
Uses manufacturer-supplied NIC driver	<ul style="list-style-type: none"> <li>• Compatible with all commercial NICs</li> <li>• Supports laptop/notebook-based interfaces</li> </ul>
Intelligent Windows stack bypass	<ul style="list-style-type: none"> <li>• High-throughput data streaming with low CPU usage and simultaneous access to corporate networks using single network interface</li> </ul>
iPORT Software Development Kit (SDK)	
Comprehensive C++ libraries	<ul style="list-style-type: none"> <li>• Simplifies development of high-performance, easily maintainable applications</li> </ul>
Windows 2000, XP, SuSe Linux, Red Hat Linux	<ul style="list-style-type: none"> <li>• Flexible choice of application platform</li> </ul>
OCX Control (display) COM+ Components (libraries) Buffer Interface	<ul style="list-style-type: none"> <li>• Fast time-to-market with custom applications using buffer interface or OCX controls</li> <li>• Compatible with third-party vision packages, such as Common Vision, eVision, Halcon, Image Pro, Labview, MIL, Sapera, Video Savant, and others.</li> </ul>
Multiple classes	<ul style="list-style-type: none"> <li>• Comprehensive toolsets for communications, imaging, device and data control and display, and configuration management</li> </ul>
Sample application source code and executables	<ul style="list-style-type: none"> <li>• Provides working applications for device configuration, data acquisition and triggering, and display and diagnostics</li> <li>• Enables instant data access and fast application development</li> </ul>
Compatible with Pleora's iPORT Hydra™ software	<ul style="list-style-type: none"> <li>• Gives applications easy access to real-time GigE pipelining architectures</li> </ul>

## Pleora's iPORT Connectivity Solution

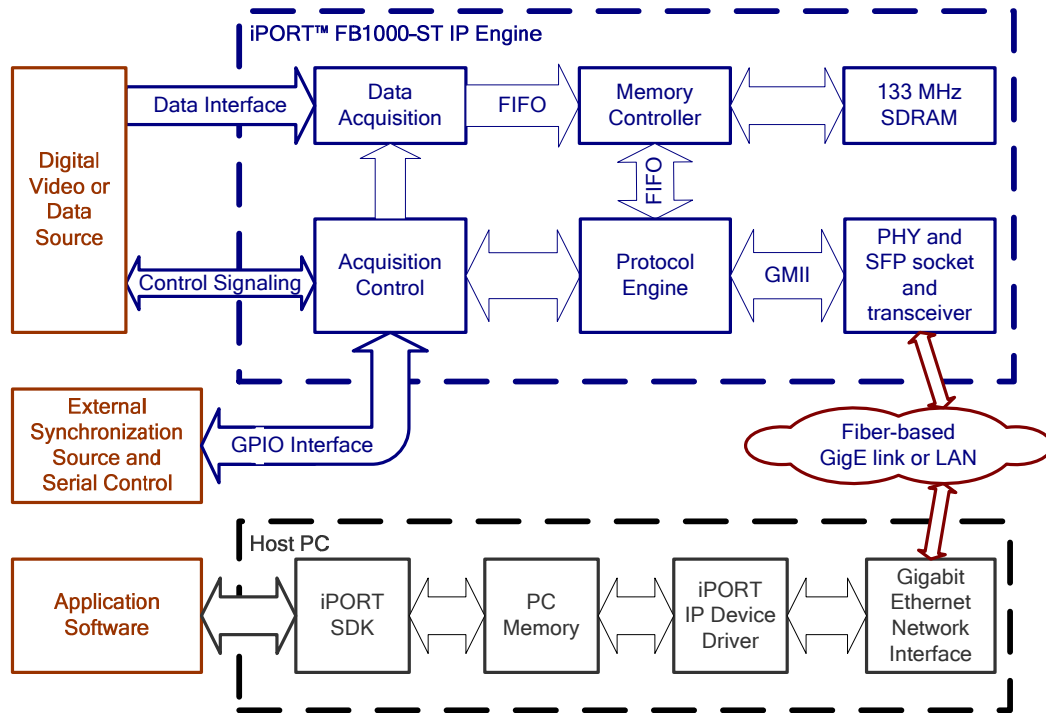

*End-to-end architecture for iPORT solution using the FB1000-ST Protocol Engine*

All products include a CD with PC driver, SDK, sample application source code, and user documentation. The Development Kit includes a power supply, an SFP transceiver, a fiber network card, and fiber cable.

**Contact Pleora for other data interfaces and configurations**

Rev 060704

Information in this document is provided in connection with Pleora Technologies products. No license, express or implied, by estoppel or otherwise, to any intellectual property rights is granted by this document. Pleora may make changes to specifications and product descriptions at any time, without notice. Other names and brands may be claimed as the property of others.