

MVS-5410

Machine Vision Strobe



Description

The PerkinElmer MVS 5410 Machine Vision Strobe is a source of short duration, high intensity light pulses used to “freeze motion” as a visual aid for machine vision applications.

The MVS 5410 is a self contained, AC-powered unit packaged in a rugged metal enclosure designed for industrial applications. It is fitted with a polycarbonate window for safety and an adjustable bracket for maximum convenience and flexibility in mounting. Its output may be externally triggered or controlled by an internal source which is adjustable from the convenient front control panel. Input cable connections and cooling vents are protectively located on the rear panel.

Line power is supplied through a line cord receptacle and a country-specific line cord which is included. External trigger input is applied through a five pin DIN connector. A control cable with mating connector is supplied with each unit.

Features

- CE Certified to EMC and Safety directives
- Internal or external triggering
- Exceptional lamp stability
- Long lamp life
- Up to 24,000 flashes per minute (400Hz)
- Microsecond flash durations
- Universal power input (90-230VAC, 50/60Hz)
- Adjustable mounting
- Easy access to control panel

MVS-5410 Strobe

Optical Specifications

	MVS-5410-10	MVS-5410-02
Spectral bandwidth	300 to 1100+ nm	300 to 1100+ nm
Flashlamp life (5)	>10 ⁸ flashes	>10 ⁸ flashes
Flash duration (1)	20 microseconds	20 microseconds
Intensity level	Adjustable from 35% to 100%	Adjustable from 35% to 100%

Illumination Characteristics

Distance	Area Illuminated	Photometric	Radiometric	Area Illuminated	Photometric	Radiometric
1 foot	15" x 15"	38 lux-sec	32 μJ/cm ²	15" x 15"	13 lux-sec	12 μJ/cm ²
2 feet	30" x 30"	10 lux-sec	9 μJ/cm ²	30" x 30"	3.5 lux-sec	3 μJ/cm ²
3 feet	45" x 45"	4 lux-sec	4 μJ/cm ²	45" x 45"	1.5 lux-sec	1.5 μJ/cm ²

Note 1: Energy per flash is constant up to 100Hz; total output power is constant from 100Hz to 200Hz. (Power = Energy x Flashrate)

Note 2: Energy per flash is constant up to 200Hz; total output power is constant from 200Hz to 400Hz. (Power = Energy x Flashrate)

Note 3: At maximum intensity. Flash to Flash Variation ±5%

Note 4: Lux = Lumen-second/meter²

Note 5: Where light output is not less than 50% of maximum value.

Electrical Specifications

Input voltage	90-230 VAC 50/60 Hz
Input current	135 W rms maximum
Power to Lamp	100 W rma maximum
External trigger:	
Pulse	+5 volt TTL pulse, 10-100 μsec into an opto-isolator with internal 150 ohm nominal resistor
Current	20 mA
Duty cycle	up to 90%
Flash delay	18μsec max from leading edge of trigger pulse
Internal trigger	Variable via 10-turn potentiometer

Environmental Specifications

Operating temperature	-10 to +110°F (-23 to +43°C)
Storage temperature	-40 to +194°F (-40 to +90°C)
Shock and vibration	1.5G, 50 to 200 Hz per MIL-STD-810C

Controls

Flash rate intensity (1 turn potentiometer) internal/external
 Flash rate (10 turn potentiometer) internal only
 Internal/External trigger switch
 Flash standby (stops flashlamps operation) internal/external
 AC Power On/OFF switch (back side of unit)

Indicators

Trigger light
 AC power light

Mechanical Specifications

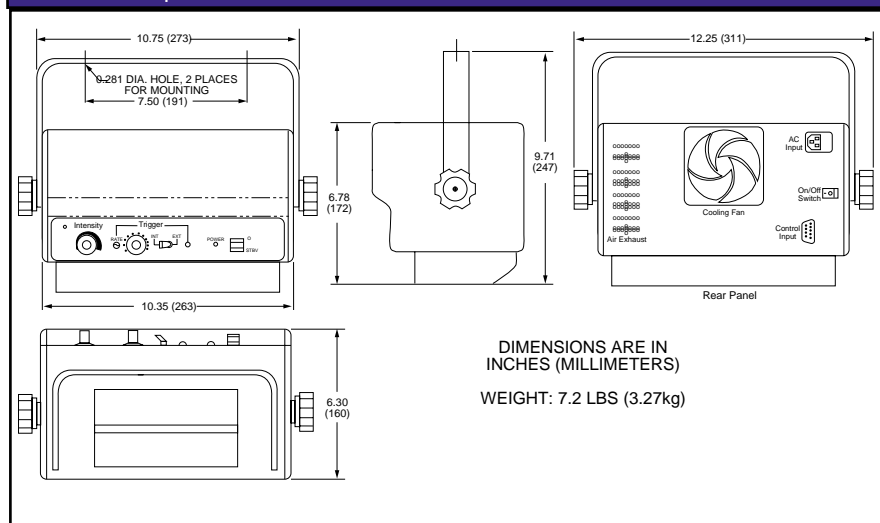

CAUTION

Some glass flashlamps are under high internal pressure, and, if broken, could result in glass particles being blown into the face and hand areas. To prevent injury, wear suitable protective devices such as safety glasses and/or face mask and goggles.

Some types of pulsed lamps generate intense ultraviolet radiation which, if not properly shielded from personnel in the area, will cause burns to any exposed skin and especially to the eyes. Do not expose any skin area or the eyes to the direct or reflected radiation of an operating lamp. If you have to view an operating lamp, always use protective covering for exposed skin area and ultraviolet-attenuating goggles for the eyes.