

DELUXE HEAVY STAND

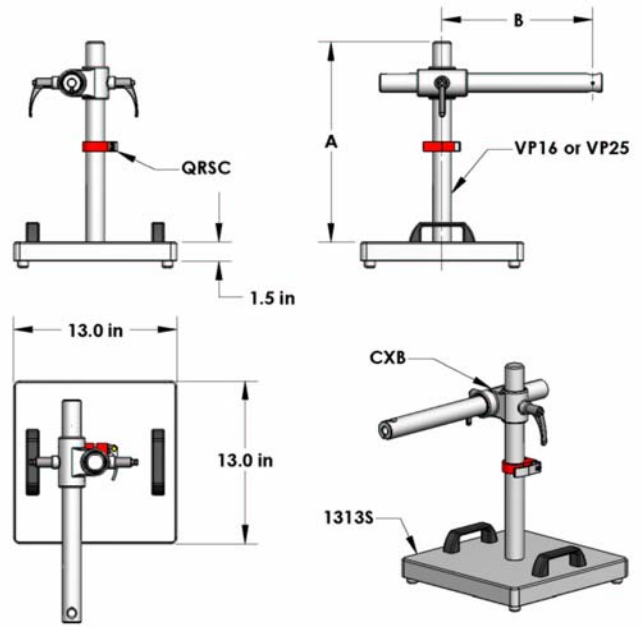

Heavy Standard Stand Components

- 1313S 13" x 13" x 1½" powder coated steel base with four rubber feet, carrying handles, 78 lbs.
- VP16 1½" diameter x 16" long stainless steel vertical post drilled to accept ½-13 UNC bolt.
- VP25 1½" diameter x 25" long stainless steel vertical post drilled to accept ½-13 UNC bolt.
- HB18 1½" diameter x 18" long keyed anodized aluminum horizontal bar with industry standard 5/8" "Bonder Pin" hole for end on, above or below mounting.
- HB25 1½" diameter x 25" long keyed anodized aluminum horizontal bar with industry standard 5/8" "Bonder Pin" hole for end on, above or below mounting.
- QRSC Red anodized aluminum safety clamp featuring a clear anodized aluminum quick release handle incorporating all stainless steel and brass hardware.
- CXB Cast aluminum, powder coated cross block with bronze bushings and adjustable handles.

Assembly Number	A* (in)	B (in)	C (in)	Stand Specific Components	Common Components
OS1313S-1618	16	14.75	1½	VP16, HB18	1313S CXB QRSC
OS1313S-2518	25	14.75	1½	VP25, HB18	
OS1313S-1625	16	21.75	1½	VP16, HB25	
OS1313S-2525	25	21.75	1½	VP25, HB25	
* Custom length vertical posts available upon request.					