

## ❖ **TM-2030 GE / TMC-2030 GE** Progressive Scan CCD



- **1" progressive scan IT CCD (Kodak KAI-2093)**
- **1920 x 1080 pixels (HDTV format)**
- **7.4  $\mu\text{m}$  square pixels**
- **32 fps in dual-tap mode**
- **SW selectable single-tap mode @ 16 fps**
- **12-bit A/D (linear) or 8-bit/10-bit with look-up table (LUT)**
- **GigE Vision Ethernet output and analog output**
- **100 m with standard CAT 5E or CAT 6 cable**
- **Full-frame shutter to 1/16,000 sec.**
- **Asynchronous reset, no-delay, pulse width control shutter**
- **Defective pixel compensation**
- **PIV (particle imaging velocimetry) mode**
- **Extensive software developer's kit (SDK)**
- **Monochrome or color**

**GigE**<sup>TM</sup>  
VISION

# Specifications for TM-2030GE/TMC-2030GE

Specifications		TM-2030GE/TMC-2030GE
Sensor		1" progressive scan interline transfer CCD
Active area		14.2mm x 8.0mm
Active pixels		1920 (H) x 1080 (V)
Cell size		7.4 μm x 7.4 μm
Readout Mode		1920 (H) x 1080 (V) @ 32 Hz (dual-tap) or 16 Hz (single-tap) selectable
Synchronization		Internal/External auto switch HD/VD, 4.0 Vp-p impedance 4.7K Ω VD= 32.3 ± 2%, non-interlace HD= 36.4 kHz ± 2%
Pixel clock		40.00 MHz
S/N ratio		>57 dB
Sensitivity	Mono Color	0.45 lux f=1.4 (no shutter) @ 32 fps, 3.6 lux f=1.4 (no shutter) @ 32 fps, Pixel sensitivity: 14 μV/e-
Video output	Analog Digital	1.0 Vp-p, 75 Ω Gigabit Ethernet (8-bit/10-bit/12-bit)
Color (RMC/TMC-2030 only)		Raw Bayer output for host-based interpolation
Gamma		Programmable LUT (Gamma 1.0 std)
Shutter speed (programmable)		1/32 to 1/16,000 sec in increments of 275 μs
Lens mount		C, F, M42 mount (use 1" format lenses)
Power		12V DC ± 10%, 690 mA (typical at 25° C)
Operating temperature		-10° C to 50° C
Vibration		7 Grms (10 Hz to 2000 Hz) Random
Shock		70 G, 11 ms, half-sine
Dimensions (H x W x L)		51 mm x 51 mm x 85 mm
Weight		215 g (without tripod)

## GUI Interface

A user-friendly graphical user interface (GUI), provided as part of the camera's extensive software development kit (SDK), allows users to control various camera functions, including:

- Shutter control for manual async. and pulse width control
- Gain control
- A/D reference voltage control
- Save settings
- Load settings
- Report settings
- LUT setting and graphic display
- Scanning mode selection and Option selections
- Channel auto balancing



The SDK also provides functions for controlling the grabbing of images, and configuring local I/Os, by means of an integrated API and a set of powerful C++ classes. Changes in the camera's acquisition modes automatically update the API for easy image acquisition. CPU usage is only a few percent, thanks to the TCP/IP offload engine.

Software available for download at [www.jai.com](http://www.jai.com)

## Spectral Response

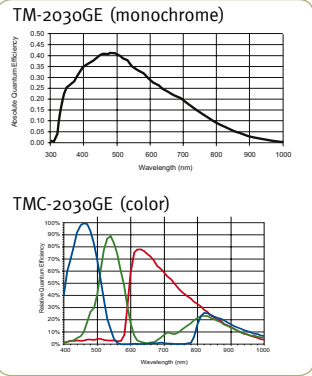

## Connector Pin-out

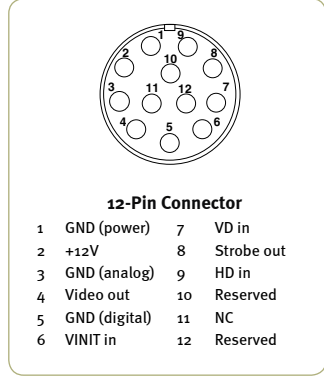

## Dimensions

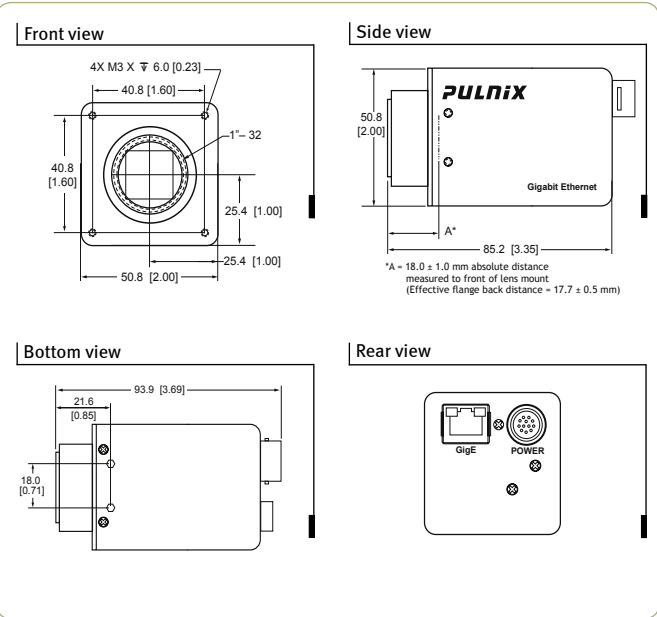

## Ordering Information

Camera	
Lead Processing	TM-2030GE (mono), TMC-2030GE (color)
RoHS Compliant	RM-2030GE (mono), RMC-2030GE (color)
Optional Functions	
Internal IR Filter Added	OP3-1
Optical Filter Removal	OP3-2 (color only)
Glassless CCD Imager	OP21
Ultraviolet Imager	OP21-UV (monochrome only)
F mount	OP65-6
M42 mount	OP65-7
M42 mount, 10mm back focus	OP65-8
Optional Accessories (must be ordered separately)	
Power Supply/2m cable	PD-12UUP/12P-02S
Power Supply	PD-12UUP series (includes power connector)

Europe, Middle East & Africa  
Phone +45 4457 8888  
Fax +45 4491 3252

Asia Pacific  
Phone +81 45 440 0154  
Fax +81 45 440 0166

Americas  
Phone (Toll-Free) 1 800 445 5444  
Phone +1 408 383 0300

Visit our web site on [www.jai.com](http://www.jai.com)

See the possibilities

