

## Datasheet

### 1. Features

- High Sensitivity and High SNR Performance Linear CCD
- 1024, 2048 or 4096 Resolution with 10  $\mu\text{m}$  Square Pixels
- 512, 1024 or 2048 Resolution with 14  $\mu\text{m}$  Square Pixels
- 100% Aperture, Built-in Anti-blooming, No Lag
- EIA-644 (LVDS) Data Format (Base Configuration)
- High Data Rate Up to 60 Mpixels/s
- Flexible and Easy to Operate via RS232 Control:
  - Gain: 0 dB to 40 dB by Step of 0.05 dB
  - Output Format: 8-, 10- or 12-bit Data
  - Offset (for Contrast Expansion)
  - Trigger Mode: Free Run or External Trigger Modes
  - Data Output Mode (Dual, Single)
- Multi Camera Synchronization
- Single Power Supply: DC 12V to 24V
- Very Compact Design: 56 x 60 x 39.4 mm (w, h, l)
- High Reliability – CE and FCC Compliant
- C or F (Nikon) Mount Adapter (Lens Not Supplied)
- T2 (M42 x 0.75) or M42 x 1 Mount Adapter (Lens Not Supplied)



### 2. Description

This camera is designed with three concepts in mind: accuracy, versatility and easy implementation.

- The same compact mechanical design incorporates all the sensors, from 512 to 4096 pixels.
- e2v manages the whole chain, from the sensor to the camera. The result is a camera able to work up to 12-bit, with dedicated electronics offering an excellent signal to noise ratio.
- The programmable settings let the user work at different integration time, gain and offset. The external clock and trigger allow the user to synchronize several cameras.

### 3. Applications

Performance and reliability of this camera make it well suited for the most demanding industrial applications, from web inspection to document scanning, from surface inspection to metrology.

## 4. Typical Performances

Table 4-1. Typical Performances

Parameter	Value				Unit
<b>Sensor Characteristics at Maximum Pixel Rate</b>					
Resolution	512	1024	2048	4096	pixels
Pixel size (square)	14 –	14 10	14 10	– 10	µm µm
Maximum line rate	98	53	28	14	kHz
Anti blooming	x 150				–
<b>Radiometric Performances (maximum Pixel Rate, T<sub>amb</sub> = 25°C)</b>					
Output Format	12 (also configurable in 8 or 10)				bit
Spectral range	250 - 1100				nm
Linearity	< 1				%
Gain range (step of 0.047 dB)	Gmin 0	Gnom 18	Gmax 30		dB
Peak response <sup>(1)(2)</sup> with 14 µm pitch 10 µm pitch	130 50	1040 400	4180 1600		LSB/(nJ/cm <sup>2</sup> ) LSB/(nJ/cm <sup>2</sup> )
Dynamic Range Effective bit	67.4 11.2	49 8.2	37 6.2		dB bit
Input RMS Noise with 14 µm pitch 10 µm pitch	14 37				pJ/cm <sup>2</sup> pJ/cm <sup>2</sup>
PRNU (Pixel Response Non Uniformity)	± 3 (± 10 max)				%
<b>Mechanical and Electrical Interface</b>					
Size (w x h x l)	56 x 60 x 39.4				mm
Lens mount	C, F, T2, M42 x 1				–
Sensor alignment (See “Sensor Alignment” on page 18)	Δx,y = ±50 – Δz = ±30 – Δtilt <sub>z</sub> = 0-35 Δθx,y = ±0.2				µm °
Power supply	DC, single 12 to 24V				V
Power dissipation	< 8				W
Operating temperature <sup>(3)</sup>	0 to 65 (non condensing)				°C
Storage temperature	-40 to 75 (non condensing)				°C
<p>Spectral Response</p> <p>Legend: — pixel 10x10 µm    — pixel 14x14 µm</p> <p>Y-axis: Relative response (%)</p> <p>X-axis: Wave length (nm)</p>					

Notes: 1. LSB are given for 12-bit configuration  
2. nJ/cm<sup>2</sup> measured on the sensor

## 3. Camera front face temperature

## 5. Camera Description

Figure 5-1. Camera Synoptic

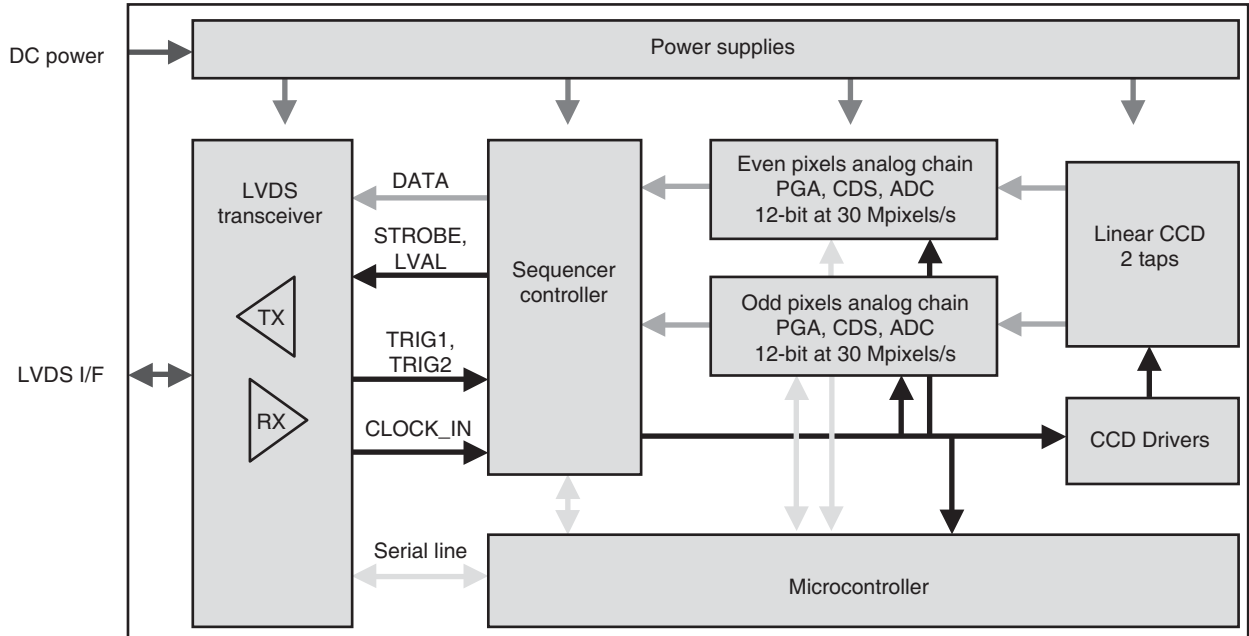

The LVDS line scan camera is based on a two-tap linear CCD. Therefore, two analog chains process odd and even pixel outputs of the linear sensor. The CCD signal processing encompasses the correlated double sampling (CDS), the dark level correction (dark pixel clamping), the gain (PGA) and offset correction and finally the analog to digital conversion on 12-bit.

Note: PGA stands for Programmable Gain Array.

The camera is powered by a single DC power supply from 12V to 24V.

The functional interface (data and control) is provided with LVDS transceivers.

The data can be delivered either on two channels or on a single multiplexed channel. The data format can be configured in 8, 10 or 12-bit.

The camera can be used with external triggers (TRIG1 and TRIG2 signals) in different trigger modes (see [“Synchronization Mode” on page 6](#)). The camera can be also clocked externally, allowing system synchronization and/or multi-camera synchronization.

The camera configuration and settings are performed via a serial line.

This interface is used for:

- Gain, offset setting
- Dynamic range, data rate setting
- Trigger mode setting: free run or external trigger modes
- Integration time setting: in free running and external trigger mode

## 6. Standard Conformity

The cameras have been tested in the following conditions:

- Shielded power supply cable
- Shielded and twisted pairs data transfer cable
- Linear AC-DC power supply

e2v recommends using the same configuration to ensure the compliance with the following standards.

### 6.1 CE Conformity

AViiVA Cameras comply with the requirements of the EMC (European) directive 89/336/CEE (EN 50081-2, EN 61000-6-2)

### 6.2 FCC Conformity

AViiVA Cameras comply with Part 15 of FCC rules.

Operation is subject to the following two conditions:

- This device may not cause harmful interference, and
- This device must accept any interference received, including interference that may cause undesired operation

This equipment has been tested and found to comply with the limits for a Class A digital device, pursuant to part 15 of the FCC Rules. These limits are designed to provide reasonable protection against harmful interference when the equipment is operated in a commercial environment. This equipment generates, uses, and can radiate radio frequency energy and, if not installed and used in accordance with the instruction manual, may cause harmful interference to radio communications. Operation of this equipment in a residential area is likely to cause harmful interference in which case the user will be required to correct the interference at his own expense.

*Warning:* Changes or modifications to this unit not expressly approved by the party responsible for compliance could void the user's authority to operate this equipment.

## 7. Camera Command and Control

Camera configuration is set through the serial interface. Please refer to “Serial Communication” on page 11 for the detailed protocol of the serial line.

**Table 7-1.** Camera Command and Control

Setting	Command	Parameter	Description
Configuration record <sup>(1)</sup>	E=	0	The camera configuration is recorded on each change
		1	The camera configuration is recorded only on request (! = 4)
Gain <sup>(2)</sup>	G=	0 to 851	Gain setting from 0 to 40 dB (~0.047dB steps)
Even Gain <sup>(2)</sup>	A=	0 to 20	Even pixels gain adjustment (odd – even mismatch adjustment)
Odd Gain <sup>(2)</sup>	B=	0 to 20	Odd pixels gain adjustment (odd – even mismatch adjustment)
Data transfer	H=	0	Two outputs on external clock
		1	One output (multiplexed) on external clock
		2	Two outputs at 10 MHz data rate
		3	One output (multiplexed) at 20 MHz data rate
		4	Two outputs at 15 MHz data rate
		5	One output (multiplexed) at 30 MHz data rate
		6	Two outputs at 20 MHz data rate
		7	One output (multiplexed) at 40 MHz data rate
		8	Two outputs at 30 MHz data rate
		9	One output (multiplexed) at 60 MHz data rate
		10	One output (multiplexed) on external clock (data frequency / 2) <sup>(6)</sup>
Output format <sup>(3)</sup>	S=	0	12-bit Output data
		1	10-bit Output data
		2	8-bit Output data
Special 2 x 8-bit mode	Y=	0	Standard: All dual output modes use the two data connectors
		1	Special: Dual 2 x 8-bit data output on a single 44-pin connector
Pattern <sup>(4)</sup>	T=	0	Standard
		1	Test pattern
Integration Time	I=	5 to 13000	Integration time ( $\mu$ s) in free run or external triggered mode
Trigger mode	M=	1	Free run with integration time setting (see timing diagram)
		2	External trigger with integration time setting (see timing diagram)
		3	Trigger and Integration time controlled
		4	Trigger and integration time controlled by two inputs
Even data Offset <sup>(5)</sup>	O=	0 to 15	Even Offset setting from 0 to approx. 200 LSB

**Table 7-1.** Camera Command and Control (Continued)

Setting	Command	Parameter	Description
Odd data Offset <sup>(5)</sup>	P=	0 to 15	Odd Offset setting from 0 to approx. 200 LSB
Special commands	!=	0	Camera identification readout
		1	User camera identification readout
		2	Software version readout
		3	Camera configuration readout
		4	Current camera configuration record
	5	Default camera configuration restoration	
User camera ID	\$=	String of Char.	Writing and record of the user camera identification

- Notes:
- e2v commends to use E = 1 because of the limited EEPROM write cycles refer on [page 12](#).
  - Camera gain (dB) = G x 0.047. A and B gain value are set in manufacturing but can be adjust if necessary.
  - Corresponding pinout in [“Connector Description”](#) on [page 12](#). If 8- or 10-bit are needed, the user can also select “S = 0” and make the cable for using the MSB.
  - The test pattern is useful to check if the interfacing is well done. The user should see a jagged image of 256 pixels steps.
- 
- The offset is set in manufacturing to balance both the channels. The initial setting is about 8 (~ 130 LSB). In some cases, the user may have to change it (for example if the ambient temperature is very high).
  - To be used for multi-camera synchronization. Refer to [Figure 8-5](#).

## 8. Timing

### 8.1 Synchronization Mode

Four different modes may be defined under user control. The TRIG1 and TRIG2 signals may be used to trigger external events and to control the integration time. The Master clock is either external or internal clock.

#### 8.1.1 Free Run Mode with Integration Time Setting

The integration and readout periods start automatically and immediately after the previous period. The read-out time depends on pixel number and pixel rate.

**Table 8-1.** Free Run Mode with Integration Time Setting

Label	Description	Min	Typ	Max
ti	Integration time duration	<sup>(1)</sup>	–	13 ms
tg	Consecutive integration period gap (at maximum frequency)	–	6 μs	–
tt	Integration period stop to read-out start delay	–	1 μs	–

- Note:
- The integration time is set by the serial line and should be higher than the read-out time (otherwise it is adjusted to the readout time).

Figure 8-1. Timing Diagram

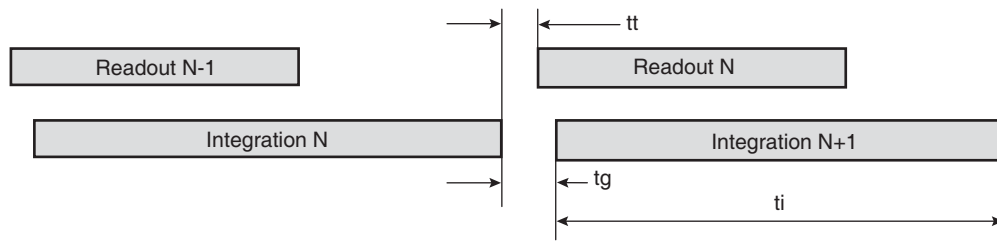

8.1.2 Triggered Mode with Integration Time Setting

The integration period starts immediately after the rising edge of TRIG1 input signal. The Integration time is set by the serial line. This integration period is immediately followed by a readout period. The read-out time depends on pixel number and the pixel rate.

Table 8-2. Triggered Mode with Integration Time Setting

Label	Description	Min	Typ	Max
ti	Integration time duration	5 $\mu$ s	–	13 ms
td	TRIG1 rising to integration period start delay	–	5.5 $\mu$ s	–
tt	Integration period stop to read-out start delay	–	1 $\mu$ s	–
ts	Integration period stop to TRIG1 rising set-up time	4 $\mu$ s	–	–
th	TRIG1 hold time (pulse high duration)	1 $\mu$ s	–	–

Figure 8-2. Timing Diagram

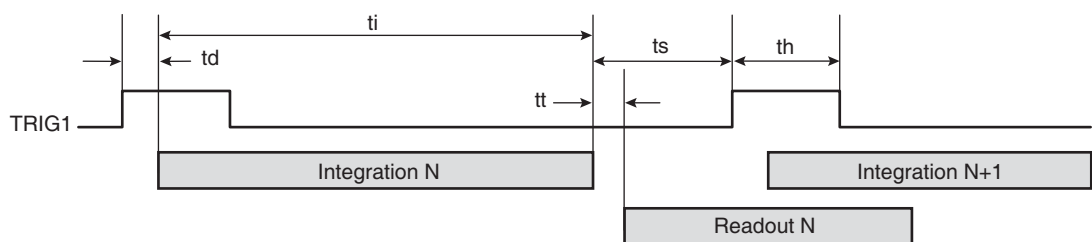

8.1.3 Trigger and Integration Time Controlled by One Input

The integration period starts immediately after the falling edge of TRIG1 input signal, stops immediately after the rising edge of TRIG1 input signal, and is immediately followed by a readout period. The read-out time depends on pixel number and pixel rate.

Table 8-3. Trigger and Integration Time Controlled by One Input

Label	Description	Min	Typ	Max
ti	Integration time duration	5 $\mu$ s	–	–
td1	TRIG1 falling to integration period start delay	–	100 ns	–
td2	TRIG1 rising to integration period stop delay	–	1.3 $\mu$ s	–
tt	Integration period stop to read-out start delay	–	1 $\mu$ s	–
th	TRIG1 hold time (pulse high duration)	1 $\mu$ s	–	–

**Figure 8-3.** Timing Diagram

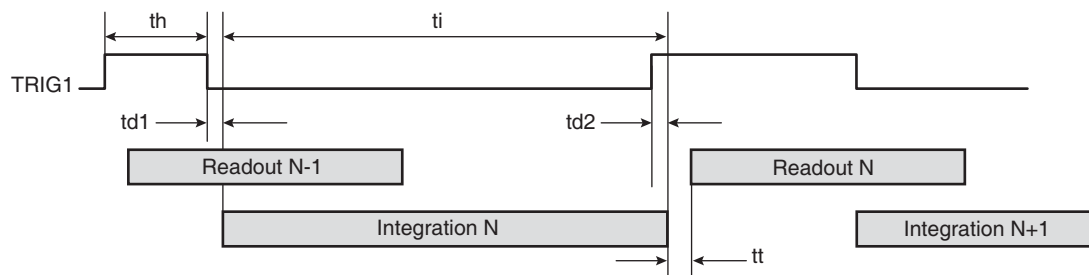

**8.1.4 Trigger and Integration Time Controlled by Two Inputs**

The TRIG2 rising edge starts the integration period. The TRIG1 rising edge stops the integration period. This period is immediately followed by a readout period.

**Table 8-4.** Trigger and Integration Time Controlled by Two Inputs

Label	Description	Min	Typ	Max
$t_i$	Integration time duration	5 $\mu$ s	–	–
$t_{d1}$	TRIG2 rising to integration period start delay	–	100 ns	–
$t_{d2}$	TRIG1 rising to integration period stop delay	–	1.3 $\mu$ s	–
$t_t$	Integration period stop to read-out start delay	–	1 $\mu$ s	–
$t_h$	TRIG1 and TRG2 hold time (pulse high duration)	1 $\mu$ s	–	–

**Figure 8-4.** Timing Diagram

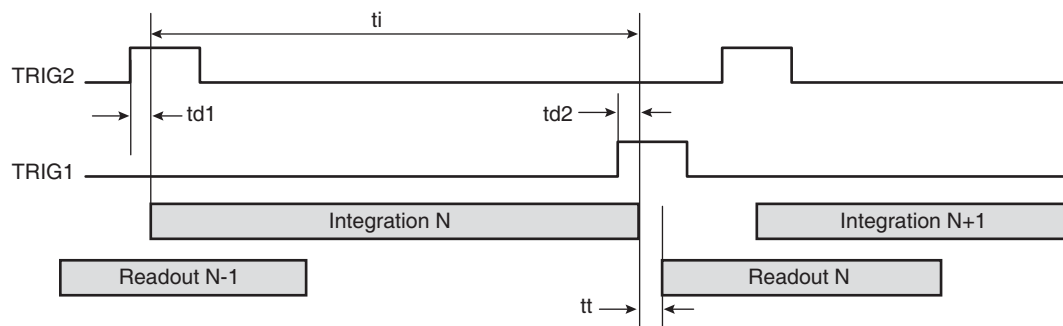

**8.2 Output Data Timing**

**Table 8-5.** Output Data Timing

Label	Description	Min	Typ	Max
$t_p$	Input falling edge to output clock propagation delay	–	7 ns	–
$t_d$	STROBE to synchronized signals delay	-5 ns	–	+5 ns

Figure 8-5. Timing Diagram

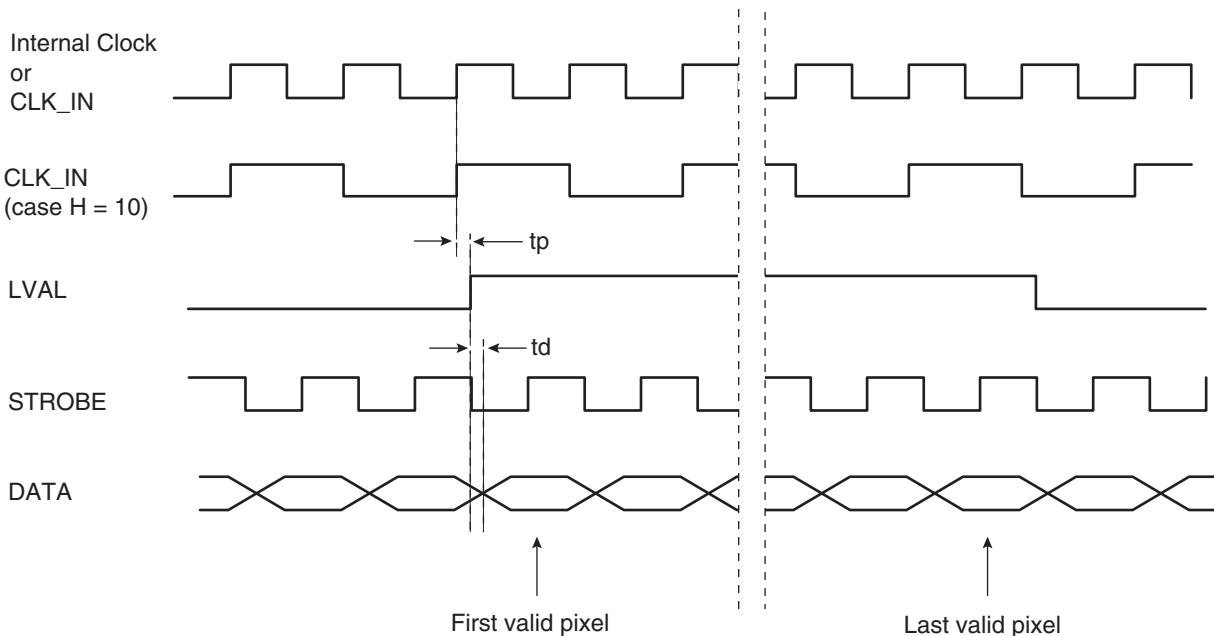

Note: CLOCK\_IN input frequency must be in the range 5 to 60 MHz. Out of this range, the performances may be decreased.

In case of *multi-cameras synchronization* (means more than one camera on one acquisition board):

- The "master" camera will provide DATA, STROBE and LVAL signals to the acquisition board. The others will only provide DATA.
- The external clock CLK\_IN must be input on each cameras to guaranty perfect data synchronization.
- The trigger(s) input (TRIG1 and/or TRIG2) must be input on each cameras. It is recommended to synchronize the rising edge of these signals on the CLK\_IN falling edge.
- Cables must be balanced between each cameras (same quality, same length) to ensure perfect cameras synchronization.
- The CLK\_IN frequency must be equal to the two CCD register frequency. It means that the user shall use either H=2 (2 taps at CLK\_IN data rate) or H=10 (1 tap at 2xCLK\_IN data rate). *Using H=1 clock mode will provide LVAL jitter on the "slave" camera.*
- Only "triggered and integration time controlled" (M=3 or M=4) can be used. These modes ensure perfect readout phase starting for each cameras.

## 9. Electrical Interface

### 9.1 Power Supply

It is recommended to insert a 1A fuse between the power supply and the camera.

**Table 9-1.** Power Supply

Signal Name	I/O	Type	Description
PWR	P	–	DC power input: +12V to +24V ( $\pm 0.5V$ )
GND	P	–	Electrical and Mechanical ground

I = input, O = output, I/O = bidirectional signal, P = power/ground, NC = not connected

### 9.2 Camera Control

The Camera interface provides three LVDS signals dedicated to camera control.

**Table 9-2.** Camera Control

Signal Name	I/O	Type	Description
TRIG1	I	RS644	Synchronization input (refer to <a href="#">“Synchronization Mode” on page 6</a> )
TRIG2	I	RS644	Start Integration period in dual synchronization mode (refer to <a href="#">“Synchronization Mode” on page 6</a> )
CLOCK_IN	I	RS644	External clock for (multi-)camera synchronization (refer to <a href="#">“Synchronization Mode” on page 6</a> )

I = input, O = output, I/O = bidirectional signal, P = power/ground, NC = not connected

### 9.3 Video Data

**Table 9-3.** Video Data

Signal Name	I/O	Type	Description
ODD[11-0]	O	RS644	Odd pixel data (refer to <a href="#">“Output Data Timing” on page 8</a> ), ODD-00 = LSB, ODD-11 = MSB
EVEN[11-0]	O	RS644	Even pixel data (refer to <a href="#">“Output Data Timing” on page 8</a> ), EVEN-00 = LSB, EVEN-11 = MSB
STROBE	O	RS644	Output data clock (refer to <a href="#">“Output Data Timing” on page 8</a> ), data valid on the rising edge
LVAL	O	RS644	Line valid (refer to <a href="#">“Output Data Timing” on page 8</a> ), active high signal

I = input, O = output, I/O = bidirectional signal, P = power/ground, NC = not connected

Note: In case of Single output, the data (multiplexed) are output in place of Odd data.

## 9.4 Serial Communication

The RS-232 interface allows to parameter the camera.

The RS-232 configuration is:

- Full duplex/without handshaking. The camera is configured in DCE/Modem
- 9600 bauds, 8-bit data, no parity bit, 1 stop bit

**Table 9-4.** Serial Communication

Signal Name	I/O	Type	Description
TX	O	RS232	Transmitted data
RX	I	RS232	Received data

### 9.4.1 Command Syntax

The valid syntax is "S = n(CR)" with:

- S: command identification as per ["Camera Command and Control" on page 5](#). S is a single character in upper case
- n: setting value
- (CR): means "carriage return"

no space, nor tab may be inserted between S, =, n and (CR).

Example of a valid command:

- G = 3(CR): sets the camera to gain 3 (refer to ["Camera Command and Control" on page 5](#) for exact value calculation)

Example of non valid commands:

- G = 3(CR): spaces
- g = 3(CR): g instead of G
- G = 1040(CR): 1040 is outside of range

### 9.4.2 Command Processing

Each command received by the camera is processed:

- If the command is valid:
  - The setting is done in case of a write command
  - The camera returns the data separated by (CR) in case of the read command
  - The camera returns: >OK(CR)
- If the command is not valid:
  - Nothing is done
  - The camera returns: >1 = out of range; >2 = syntax error; >3 = command too long; >4,>6,>7 = internal error; >5 undefined function

Example: when receiving "! = 3(CR)" the camera returns its current settings:

- A = 0(CR); B = 0(CR); ....; E = 0(CR); >OK(CR).

## 9.5 Storage of the Settings in EEPROM

e2v recommends to use "E = 1" for settings that are often changed (check the maximum number of write cycles above) and when the time required by the camera to process a command is critical. The maximum number of write cycles allowed for the EEPROM is: 100 000.

## 10. Connector Description

All connectors are on the rear panel.

Note: Cables for digital signals shall be shielded twisted pairs.

### 10.1 Power Supply

Camera connector type: Hirose HR10A-7R-6PB (male).

Cable connector type: Hirose HR10A-7P-6S (female).

**Table 10-1.** Power Supply Connector Pin-out

Signal	Pin	Signal	Pin
PWR	1	GND	4
PWR	2	GND	5
PWR	3	GND	6

**Figure 10-1.** Receptacle Viewed from Camera Back

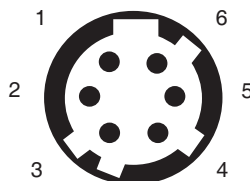

## 10.2 RS232 Connector

Camera connector type: D-Sub 9-pin female.

RTS (pin 4) and CTS (pin 6) are connected together inside the camera.

DTR (pin 7) and DSR (pin 8) are connected together inside the camera.

**Table 10-2.** RS232 Connector Pin-out

Signal	Pin	Signal	Pin	Signal	Pin
NC	1	RTS	4	DTR	7
TX	2	GND	5	DSR	8
RX	3	CTS	6	NC	9

## 10.3 44-pin Data and Synchro Connector

Camera connector type: D-Sub HD 44-pin female.

Warning: *Unused pins must be kept open.*

When used in Single (multiplexed) output, the multiplexed data are output in place of ODD data.

**Table 10-3.** 44-pin Data and Synchro Connector when Used in 12-bit Output Format (S = 0)

Pin	Signal	Pin	Signal	Pin	Signal	Pin	Signal
1	GND	12	–	23	ODD-03+	34	ODD-06-
2	CLOCK_IN+	13	–	24	ODD-08+	35	ODD-07+
3	ODD-04-	14	LVAL+	25	ODD-10-	36	ODD-01+
4	ODD-05-	15	STROBE+	26	ODD-11-	37	ODD-02+
5	ODD-07-	16	CLOCK_IN-	27	–	38	ODD-03-
6	ODD-00+	17	TRIG1+	28	–	39	ODD-09+
7	ODD-02-	18	TRIG1-	29	LVAL-	40	ODD-10+
8	ODD-08-	19	ODD-05+	30	STROBE-	41	–
9	ODD-09-	20	ODD-06+	31	TRIG2-	42	–
10	ODD-11+	21	ODD-00-	32	TRIG2+	43	–
11	–	22	ODD-01-	33	ODD-04+	44	GND

**Table 10-4.** 44-pin Data and Synchro Connector when Used in 10-bit Output Format (S = 1)

Pin	Signal	Pin	Signal	Pin	Signal	Pin	Signal
1	GND	12	–	23	ODD-03+	34	ODD-06-
2	CLOCK_IN+	13	–	24	ODD-08+	35	ODD-07+
3	ODD-04-	14	LVAL+	25	–	36	ODD-01+
4	ODD-05-	15	STROBE+	26	–	37	ODD-02+
5	ODD-07-	16	CLOCK_IN-	27	–	38	ODD-03-
6	ODD-00+	17	TRIG1+	28	–	39	ODD-09+
7	ODD-02-	18	TRIG1-	29	LVAL-	40	–
8	ODD-08-	19	ODD-05+	30	STROBE-	41	–
9	ODD-09-	20	ODD-06+	31	TRIG2-	42	–
10	–	21	ODD-00-	32	TRIG2+	43	–
11	–	22	ODD-01-	33	ODD-04+	44	GND

**Table 10-5.** 44-pin Data and Synchro Connector when Used in 8-bit Output Format (S = 2)

Pin	Signal	Pin	Signal	Pin	Signal	Pin	Signal
1	GND	12	–	23	ODD-03+	34	ODD-06-
2	CLOCK_IN+	13	–	24	–	35	ODD-07+
3	ODD-04-	14	LVAL+	25	–	36	ODD-01+
4	ODD-05-	15	STROBE+	26	–	37	ODD-02+
5	ODD-07-	16	CLOCK_IN-	27	–	38	ODD-03-
6	ODD-00+	17	TRIG1+	28	–	39	–
7	ODD-02-	18	TRIG1-	29	LVAL-	40	–
8	–	19	ODD-05+	30	STROBE-	41	–
9	–	20	ODD-06+	31	TRIG2-	42	–
10	–	21	ODD-00-	32	TRIG2+	43	–
11	–	22	ODD-01-	33	ODD-04+	44	GND

**Table 10-6.** 44-pin Data and Synchro Connector when Used in Special 2 x 8-bit Output on a Single Connector (Y = 1)

Pin	Signal	Pin	Signal	Pin	Signal	Pin	Signal
1	GND	12	EVEN-06-	23	ODD-03+	34	ODD-06-
2	CLOCK_IN+	13	EVEN-07-	24	EVEN-00+	35	ODD-07+
3	ODD-04-	14	LVAL+	25	EVEN-02-	36	ODD-01+
4	ODD-05-	15	STROBE+	26	EVEN-03-	37	ODD-02+
5	ODD-07-	16	CLOCK_IN-	27	EVEN-05+	38	ODD-03-
6	ODD-00+	17	TRIG1+	28	EVEN-06+	39	EVEN-01+
7	ODD-02-	18	TRIG1-	29	LVAL-	40	EVEN-02+
8	EVEN-00-	19	ODD-05+	30	STROBE-	41	EVEN-04-
9	EVEN-01-	20	ODD-06+	31	TRIG2-	42	EVEN-05-
10	EVEN-03+	21	ODD-00-	32	TRIG2+	43	EVEN-07+
11	EVEN-04+	22	ODD-01-	33	ODD-04+	44	GND

## 10.4 26-pin Data Connector

Camera connector type: D-Sub HD 26-pin female.

In case of single (multiplexed) or special 2 x 8-bit mode, the output on this connector are all fixed to low level.

**Table 10-7.** 26-pin Data Connector when Used in 12-bit Output Format (S = 0)

Pin	Signal	Pin	Signal	Pin	Signal	Pin	Signal
1	GND	8	EVEN-10+	15	EVEN-07+	22	EVEN-05+
2	EVEN-01-	9	EVEN-11-	16	EVEN-08+	23	EVEN-06+
3	EVEN-03+	10	EVEN-00-	17	EVEN-10-	24	EVEN-08-
4	EVEN-04+	11	EVEN-01+	18	EVEN-11+	25	EVEN-09-
5	EVEN-06-	12	EVEN-02+	19	EVEN-00+	26	GND
6	EVEN-07-	13	EVEN-04-	20	EVEN-02-		
7	EVEN-09+	14	EVEN-05-	21	EVEN-03-		

**Table 10-8.** 26-pin Data Connector when Used in 10-bit Output Format (S = 1)

Pin	Signal	Pin	Signal	Pin	Signal	Pin	Signal
1	GND	8	–	15	EVEN-07+	22	EVEN-05+
2	EVEN-01-	9	–	16	EVEN-08+	23	EVEN-06+
3	EVEN-03+	10	EVEN-00-	17	–	24	EVEN-08-

**Table 10-8.** 26-pin Data Connector when Used in 10-bit Output Format (S = 1) (Continued)

Pin	Signal	Pin	Signal	Pin	Signal	Pin	Signal
4	EVEN-04+	11	EVEN-01+	18	–	25	EVEN-09-
5	EVEN-06-	12	EVEN-02+	19	EVEN-00+	26	GND
6	EVEN-07-	13	EVEN-04-	20	EVEN-02-		
7	EVEN-09+	14	EVEN-05-	21	EVEN-03-		

**Table 10-9.** 26-pin Data Connector when Used in 8-bit Output Format (S = 2)

Pin	Signal	Pin	Signal	Pin	Signal	Pin	Signal
1	GND	8	–	15	EVEN-07+	22	EVEN-05+
2	EVEN-01-	9	–	16	–	23	EVEN-06+
3	EVEN-03+	10	EVEN-00-	17	–	24	–
4	EVEN-04+	11	EVEN-01+	18	–	25	–
5	EVEN-06-	12	EVEN-02+	19	EVEN-00+	26	GND
6	EVEN-07-	13	EVEN-04-	20	EVEN-02-		
7	–	14	EVEN-05-	21	EVEN-03-		

## 11. Mechanical Characteristics

### 11.1 Weight

The camera typical weight (without lens nor lens adapter) is 220 g/7.7 ounces (typical).

### 11.2 Dimensions

The camera dimensions (without lens) are W = 56 mm, H = 60 mm, L = 39.4 mm.

Figure 11-1. Mechanical Box Drawing and Dimensions

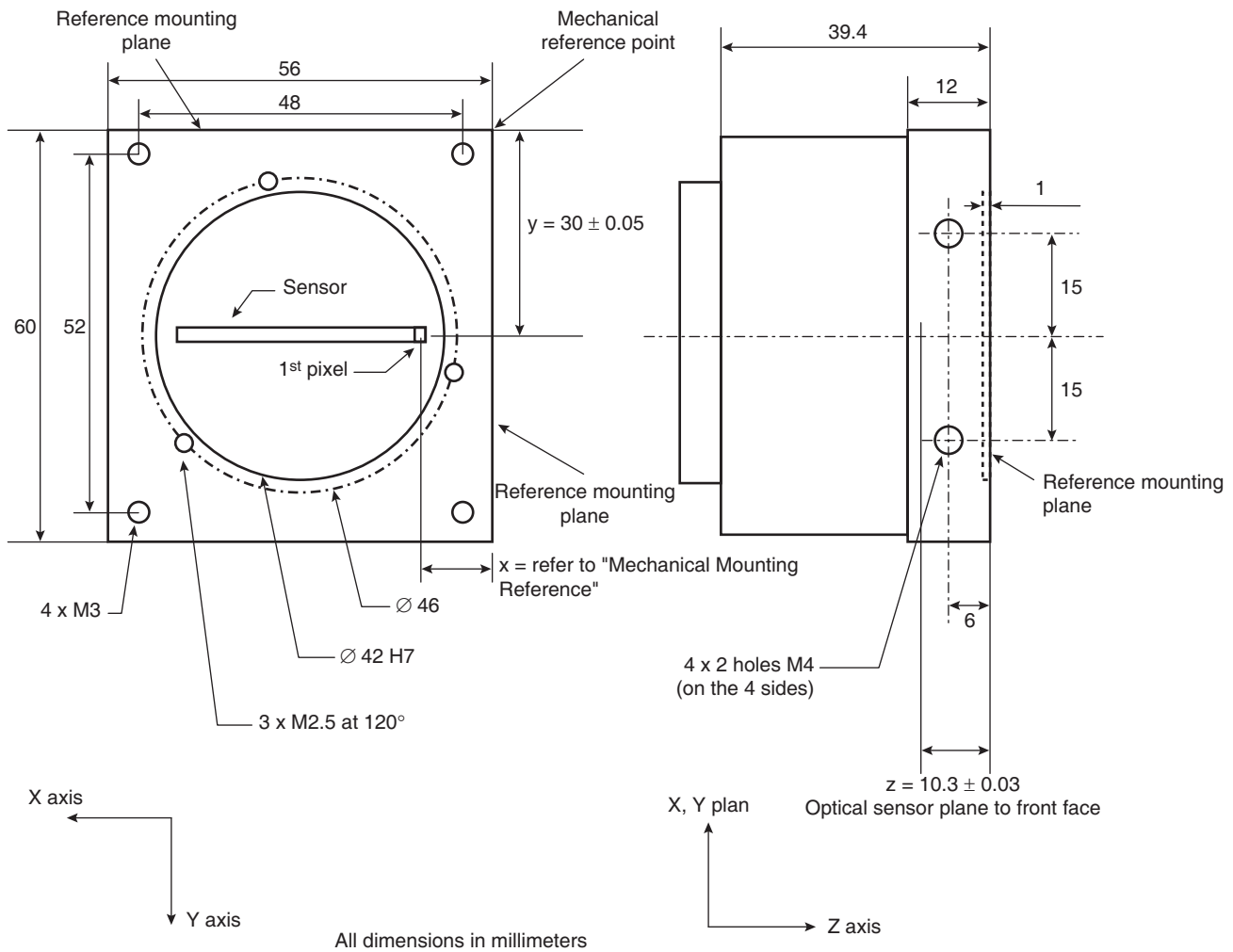

### 11.3 Mechanical Mounting Reference

The front panel mechanical part is designed to support the mounting of the camera. On this mechanical part, three surfaces are considered as mounting reference surface: i.e. the distance between these surfaces and the first active pixel are known very precisely (better than  $\pm 50 \mu\text{m}$ ).

Table 11-1. Mechanical Mounting Reference

Number of Pixel	512	1024	2048	4096
x with 14 $\mu\text{m}$ sensor (nm)	24.416	20.832	13.664	–
x with 10 $\mu\text{m}$ sensor (nm)	–	22.880	17.760	7.520

## 11.4 Sensor Alignment

Figure 11-2. Sensor Alignment Diagram

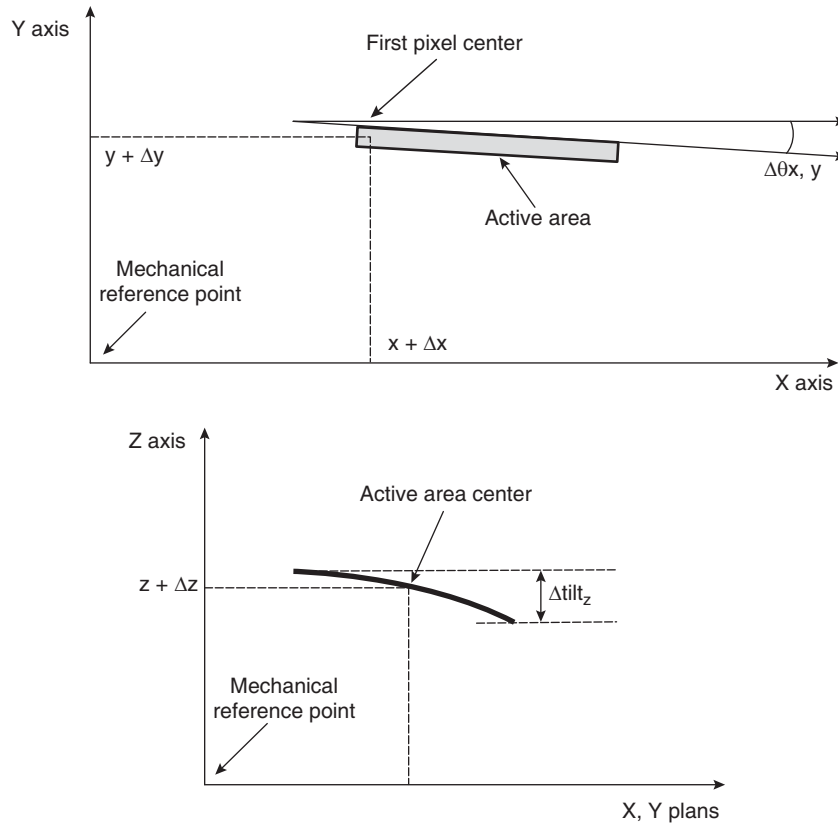

## 11.5 Lens Mounting (Lens Not Supplied)

The camera can be provided with three different lens adapter, corresponding to three different options. The customer has to selected the correct adapter. The following table gives recommendation according to the sensor size.

Table 11-2. Lens Mounting

Number of Pixel	512/14 μm	1024/10 μm	1024/14 μm	2048/10 μm	2048/14 μm	4096/10 μm
C mount	OK	OK	~OK <sup>(1)</sup>	~OK <sup>(1)</sup>	not usable	not usable
F mount	OK	OK	OK	OK	OK	OK

Note: 1. Depends on the lens quality.

## 11.6 Heat-sink Mounting

In order to improve the power dissipation, the camera can be delivered with heat-sink to be mounted by the user on the side faces of the camera. The delivery of the heat-sinks corresponds to a dedicated option.

## 12. Ordering Code

**Table 12-1.** Ordering Code

Part Number	Resolution	Pixels size	Description
AT71M2LV1010-BA0	1K	10 µm	AViiVA M2 LV 1010
AT71M2LV2010-BA0	2K	10 µm	AViiVA M2 LV 2010
AT71M2LV4010-BA0	4K	10 µm	AViiVA M2 LV 4010
AT71M2LV0514-BA0	512	14 µm	AViiVA M2 LV 0514
AT71M2LV1014-BA0	1K	14 µm	AViiVA M2 LV 1014
AT71M2LV2014-BA0	2K	14 µm	AViiVA M2 LV 2014
AT71KFPVIVA-ABA	–	–	F mount (NIKON)
AT71KFPVIVA-AKA	–	–	T2 mount (M42 x 0.75)
AT71KFPAAVIVA-ADA	–	–	M42 x 1 mount
AT71KFPVIVA-ACA	–	–	C mount
AT71KAVIVAP2C0D4A0	–	–	Cables kit: 10m power supply and 5m LVDS data transmission cables



## How to reach us

Home page: [www.e2v.com](http://www.e2v.com)

### Sales Office:

#### **Northern Europe**

##### **e2v ltd**

106 Waterhouse Lane  
Chelmsford  
Essex CM1 2QU  
England  
Tel: +44 (0)1245 493493  
Fax: +44 (0)1245 492492  
E-Mail: [enquiries@e2v.com](mailto:enquiries@e2v.com)

#### **Southern Europe**

##### **e2v sas**

16 Burospace  
F-91572 Bièvres  
Cedex  
France  
Tel: +33 (0) 16019 5500  
Fax: +33 (0) 16019 5529  
E-Mail: [enquiries-fr@e2v.com](mailto:enquiries-fr@e2v.com)

#### **Germany and Austria**

##### **e2v gmbh**

Industriestraße 29  
82194 Gröbenzell  
Germany  
Tel: +49 (0) 8142 41057-0  
Fax: +49 (0) 8142 284547  
E-Mail: [enquiries-de@e2v.com](mailto:enquiries-de@e2v.com)

#### **Americas**

##### **e2v inc.**

4 Westchester Plaza  
Elmsford  
NY 10523-1482  
USA  
Tel: +1 (914) 592 6050 or  
1-800-342-5338,  
Fax: +1 (914) 592-5148  
E-Mail: [enquiries-na@e2v.com](mailto:enquiries-na@e2v.com)

#### **Asia Pacific**

##### **e2v**

Bank of China Tower  
30th floor office 7  
1 Garden Rd Central  
Hong Kong  
Tel: +852 2251 8227/8/9  
Fax: +852 2251 8238  
E-Mail: [enquiries-hk@e2v.com](mailto:enquiries-hk@e2v.com)

#### **Product Contact:**

##### **e2v**

Avenue de Rochepleine  
BP 123 - 38521 Saint-Egrève Cedex  
France  
Tel: +33 (0)4 76 58 30 00

##### **Hotline:**

[hotline-cam@e2v.com](mailto:hotline-cam@e2v.com)



Whilst e2v has taken care to ensure the accuracy of the information contained herein it accepts no responsibility for the consequences of any use thereof and also reserves the right to change the specification of goods without notice. e2v accepts no liability beyond that set out in its standard conditions of sale in respect of infringement of third party patents arising from the use of tubes or other devices in accordance with information contained herein.