

Datasheet

1. Features

- High Sensitivity and High Dynamic Range Performance Linear CCD Sensor
- 1024, 2048 or 4096 Resolution with 10 μm Square Pixels
- 512, 1024 or 2048 Resolution with 14 μm Square Pixels
- 100% Aperture, Built-in Anti-blooming, No Lag
- EIA-644 (LVDS) Data Format
- High Data Rate up to 60 Mpixels/s
- Flexible and Easy to Operate via RS-232 Control:
 - Exposure Time: 1 to 32 ms
 - Analog Gain: -2 dB to 28 dB by Steps of 0.035 dB
 - Digital Gain: 0 dB to 30 dB
 - Bit Depth: 8, 10 or 12-bit Data on One or Two Outputs
 - Offset (for Contrast Expansion)
 - Trigger Mode: Free-run or External Trigger Modes
- Flat-field Correction (Lens and Light Non-uniformity and FPN and PRNU Correction)
- Multi-camera Synchronization
- Single Power Supply: DC 12 to 24V
- Very Compact Design: 56 x 60 x 39.4 mm (w, h, l)
- High Reliability – CE and FCC Compliant
- C, F (Nikon), T2 (M42 x 0.75) or M42 x 1 Mount Adapter (Lens not Supplied)



2. Description

This smarter M2 offers the best in line scan cameras, with an increasingly improved accuracy, versatility and easy implementation. The AViiVA® SM2 takes advantage of all the features that made the success of the AViiVA M2, with additional flat-field correction and contrast expansion functions. The same compact mechanical design incorporates all sensors, from 512 to 4096 pixels. e2v manages the entire manufacturing process, from the sensor to the camera. The result is a camera able to operate in up to 12 bits, with dedicated electronics offering an excellent signal to noise ratio. The programmable settings let the user work at different integration times, gains and offsets. The external clock and trigger enable synchronization of several cameras.

3. Applications

The performance and reliability of this camera make it well-suited for the most demanding industrial applications, from web inspection to document scanning, from surface inspection to metrology.

4. Typical Performances

Table 4-1. Typical Performances

Parameter	Value				Unit
Sensor Characteristics at Maximum Pixel Rate					
Resolution	512	1024	2048	4096	Pixels
Pixel size (square)	14 –	14 10	14 10	– 10	µm µm
Maximum line rate	98	53	28	14	kHz
Anti-blooming	x 100				–
Radiometric Performances (Maximum Pixel Rate, Tamb = 25°C)					
Bit Depth	12 (also configurable in 8 or 10)				bit
Spectral range	250 - 1100				nm
Linearity (G = 0)	< 2				%
Gain range (step of 0.035 dB)	Gmin -2	Gnom 0	Gmax 28		dB
Peak response ⁽¹⁾⁽²⁾ with 14 µm pitch 10 µm pitch	115 46	145 58	3634 1455		LSB/(nJ/cm ²) LSB/(nJ/cm ²)
Dynamic Range	66	64	36		dB
Input RMS noise with14 µm pitch10 µm pitch	16 39				pJ/cm ² pJ/cm ²
PRNU (Photo Response Non-uniformity)	± 3% (± 10% max)				%
Mechanical and Electrical Interface					
Size (w x h x l)	56 x 60 x 39.4				mm
Lens mount	C, F, T2, M42 x 1				–
Sensor alignment (See “Sensor Alignment” on page 17)	Δx,y = ±50 – Δz = ±30 – Δtilt _z = 0-35 Δθx,y = ±0.2				µm °
Power supply	DC, single 12 to 24V				V
Power dissipation	< 8.5				W
Operating temperature ⁽³⁾	0 to 65 (non condensing)				°C
Storage temperature	-40 to 75 (non condensing)				°C
Spectral Response (peak response at 730 nm)					

- Notes:
1. LSBs are given for a 12-bit configuration
 2. nJ/cm² measured on the sensor
 3. Camera's front face temperature

5. Camera Description

Figure 5-1. Camera Synoptic

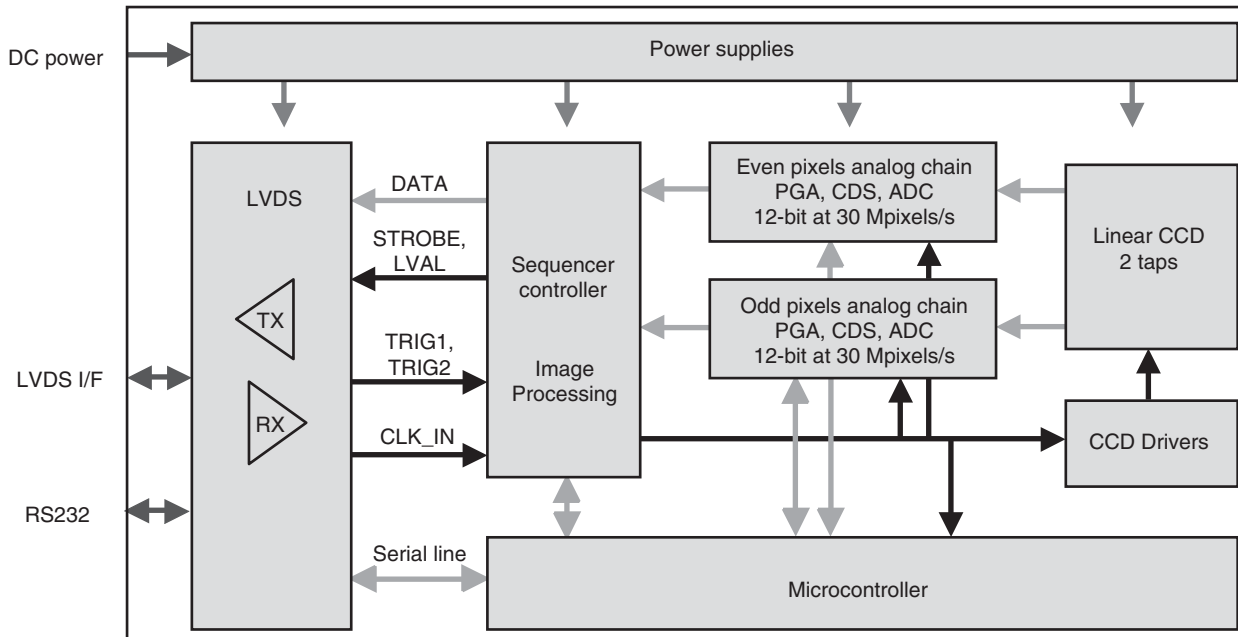

The camera is based on a two-tap linear CCD. Therefore, two analog chains process the odd and even pixel outputs of the linear sensor. The CCD signal processing encompasses the correlated double sampling (CDS), the dark level correction (dark pixel clamping), the gain (PGA) and offset correction, and finally the analog-to-digital conversion in 12 bits. An FPGA has been implemented for image processing (flat-field correction, dynamic selection and test pattern generation).

Note: PGA stands for Programmable Gain Array.

The camera is powered by a single DC power supply from 12 to 24V.

The functional interface (data and control) is provided with LVDS transceivers.

Data can be delivered on two channels or on a single multiplexed channel. The data format can be configured in 8, 10 or 12 bits.

The camera can be used with external triggers (TRIG1 and TRIG2 signals) in different trigger modes (see [“Synchronization Mode” on page 7](#)). The camera can also be clocked externally, allowing system synchronization and/or multi-camera synchronization.

The camera configuration and settings are done via a serial line, used for:

- Gain and offset settings
- Dynamic range data rate setting
- Trigger mode setting: free-run or external trigger modes
- Integration time setting: in free-run and external trigger mode
- Flat field correction, contrast expansion

6. Standard Conformity

The AViiVA cameras have been tested using the following equipment:

- A shielded power supply cable
- Shielded and twisted pairs data transfer cable
- A linear AC-DC power supply

e2v recommends using the same configuration to ensure compliance with the following standards.

6.1 CE Conformity

The AViiVA cameras comply with the requirements of the EMC (European) directive 89/336/CEE (EN 50081-2, EN 61000-6-2).

6.2 FCC Conformity

The AViiVA cameras further comply with Part 15 of the FCC rules, which states that:

Operation is subject to the following two conditions:

- This device may not cause harmful interference, and
- This device must accept any interference received, including interference that may cause undesired operation

This equipment has been tested and found to comply with the limits for a Class A digital device, pursuant to part 15 of the FCC Rules. These limits are designed to provide reasonable protection against harmful interference when the equipment is operated in a commercial environment. This equipment generates, uses, and can radiate radio frequency energy and, if not installed and used in accordance with the instruction manual, may cause harmful interference to radio communications. Operation of this equipment in a residential area is likely to cause harmful interference in which case the user will be required to correct the interference at his own expense.

Warning: Changes or modifications to this unit not expressly approved by the party responsible for compliance could void the user's authority to operate this equipment.

7. Camera Command and Control

The camera's configuration is set through the serial interface. Please refer to “Serial Communication” on page 10 for the serial line's detailed protocol.

Table 7-1. Camera Command and Control

Setting	Command	Parameter	Description
Global gain ⁽¹⁾	G=	-65 to 811	Gain setting from -2 to 28 dB (~0.035 dB steps)
Even Gain ⁽¹⁾	A=	0 to 56	Even pixels gain adjustment (odd – even mismatch adjustment)
Odd Gain ⁽¹⁾	B=	0 to 56	Odd pixels gain adjustment (odd – even mismatch adjustment)
Number of outputs	D=	0 1	One tap (odd and even data multiplexed) Two taps
Data transfer	H=	0 1 2 3 4 5 6	External clock (data rate = 2 x external clock) ⁽⁵⁾ External clock (data rate = external clock) External clock (data rate = external clock/2) 2 x 10 MHz data rate (20 MHz in one tap) 2 x 15 MHz data rate (30 MHz in one tap) 2 x 20 MHz data rate (40 MHz in one tap) 2 x 30 MHz data rate (60 MHz in one tap)
Bit Depth ⁽²⁾	S=	0 1 2	12-bit output data 10-bit output data 8-bit output data
Special 2 x 8-bit mode	Y=	0 1	Standard: all dual output modes use the two data connectors Special: dual 2 x 8-bit data output on a single 44-pin connector
Image source ⁽³⁾	T=	0 1 2	Sensor raw image Test pattern Sensor corrected image (flat-field correction enabled)
Configuration recall	+C=	0 1 to 4	Restore the default configuration Restore the user configuration 1 to 4
Configuration storage	-C=	1 to 4	Store the user configuration 1 to 4
FPN recall	+F=	1 to 4	Restore FPN factors from the FPN bank 1 to 4
FPN storage	-F=	1 to 4	Store the active FPN factors in the FPN bank 1 to 4
PRNU recall	+P=	1 to 4	Restore the PRNU factors from the PRNU bank 1 to 4
PRNU storage	-P=	1 to 4	Store the active PRNU factors in the PRNU bank 1 to 4
Integration time	I=	1 to 32768	Integration time (μ s) in free-run or external triggered mode
Trigger mode	M=	1 2 3 4	Free-run with integration time setting (see Figure 8-1 on page 7) External trigger with integration time setting (see Figure 8-2 on page 7) Trigger and Integration time controlled (see Figure 8-3 on page 8) Trigger and integration time controlled by two inputs (see Figure 8-4 on page 8)
Even data offset ⁽⁴⁾	O=	0 to 255	Even Offset setting from 0 to 255 LSB
Odd data offset ⁽⁴⁾	P=	0 to 255	Odd Offset setting from 0 to 255 LSB
Contrast expansion	Q= R=	-4096 to 4095 0 to 255	Negative digital offset in LSB/12 bits Digital gain x1 to x33 (0.125 steps)

Table 7-1. Camera Command and Control (Continued)

Setting	Command	Parameter	Description
Write FPN ⁽⁸⁾	WFP=		Send FPN values
Read FPN ⁽⁹⁾	RFP=		Read FPN values
Write PRNU ⁽⁸⁾	WPR=		Send PRNU values
Read PRNU ⁽⁹⁾	RPR=		Read PRNU values
Special commands	!=	0	Camera identification readout
		1	User camera identification readout
		2	Software version readout
		3	Camera configuration readout
		4	Status readout
		5	Start FPN calibration ⁽⁶⁾
		6	Start PRNU calibration ⁽⁷⁾
		9	Abort calibration
User camera ID	\$=	String	Write user camera identification (50 characters maximum)

- Notes:
1. Camera gain (dB) = G x 0.0353. A and B gain values are set during manufacturing but can be adjusted if necessary.
 2. Refer to tables in sections entitled “44-Pin Data and Synchro Connector” on page 13 and “26-pin Data Connector” on page 15.
 3. The test pattern is useful for checking if the device is correctly interfaced. The user should see a jagged image of 512 pixel steps.



4. The offset is set during manufacturing to balance both channels. The initial setting is about 130 LSB. In some cases, the user may have to change it (for example if the ambient temperature is very high).
5. To be used for multi-camera synchronization. Refer to Figure 8-5 on page 9.
6. Switch off all lights before starting the FPN (dark) calibration. It must be done before the PRNU calibration.
7. Place a white reference in front of the camera before starting the PRNU (white light) calibration. The light level must be between half and full dynamic range.
8. Parameter format: <addr><size><value><value>...
 <addr> = pixel number
 <size> = amount of data sent
 <value> = parameter value (0 to 255 for FPN [0 to 255 LSB]; 0 to 16383 for PRNU [x1 to x2 gain])
 Parameters are sent from <addr> to <addr> + 5 pixels maximum
9. Parameter format: <addr><size>

8. Timing

8.1 Synchronization Mode

Four different modes may be defined by the user. The TRIG1 and TRIG2 signals may be used to trigger external events and control the integration time. A missing trigger is indicated by a rear face DEL flickering.

Table 8-1. Timing Specifications

Label	Description	Min	Typ	Max
ti	Integration time duration	1 μ s	–	–
td	TRIG1 rising to integration period start delay	–	300 ns	–
tt	Integration period stop to readout start delay	37/data rate		
ts	Integration period stop to TRIG1 rising set-up time	1 μ s	–	–
th	TRIG1 or TRIG2 hold time (high pulse duration)	0.1 μ s	–	–
td1	Integration start delay		200 ns	
td2	Integration stop delay	68/data rate		
	Line frequency	Data rate/(number of pixels + 100)		

8.1.1 Free Run Mode with Integration Time Setting

The integration and readout periods start automatically and immediately after the previous period.

Note: The integration time is set by the serial line and should be higher than the readout time (otherwise it is adjusted to the readout time).

Figure 8-1. Timing Diagram

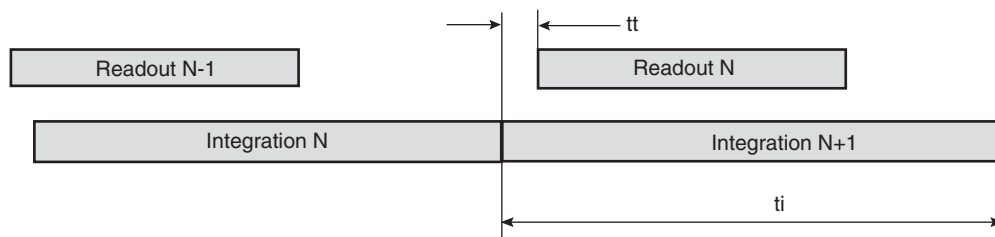

8.1.2 Triggered Mode with Integration Time Setting

The integration period starts immediately after the rising edge of the TRIG1 input signal and is set by the serial line. This period is immediately followed by a readout period..

Figure 8-2. Timing Diagram

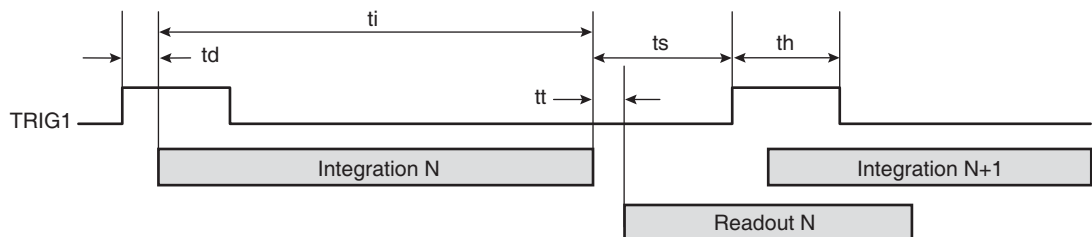

8.1.3 Trigger and Integration Time Controlled by One Input

The integration period starts immediately after the falling edge of the TRIG1 input signal, stops immediately after the rising edge of TRIG1 input signal, and is immediately followed by a readout period.

Figure 8-3. Timing Diagram

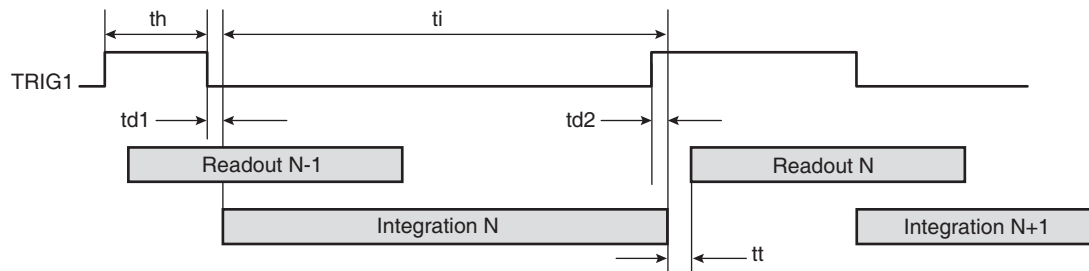

8.1.4 Trigger and Integration Time Controlled by Two Inputs

The TRIG2 signal's rising edge starts the integration period and the TRIG1 signal's rising edge stops the integration period. This period is immediately followed by a readout period.

Figure 8-4. Timing Diagram

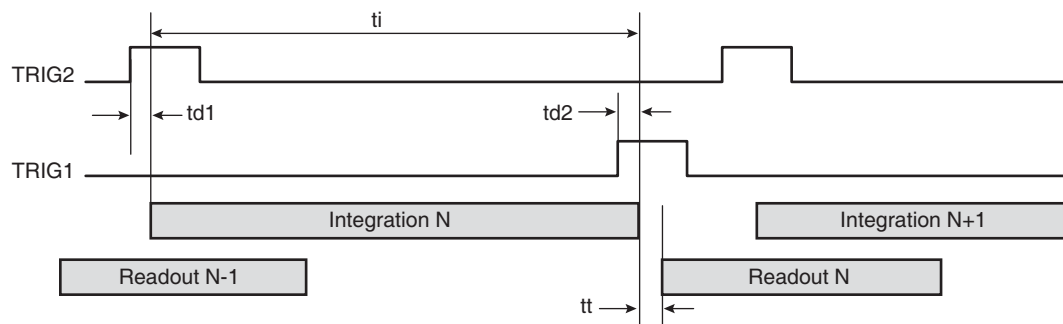

8.2 Output Data Timing

Table 8-2. Output Data Timing

Label	Description	Min	Typ	Max
t_p	Input falling edge to output clock propagation delay	-	7 ns	-
t_d	STROBE to synchronized signals delay	-5 ns	-	+5 ns

Figure 8-5. Timing Diagram

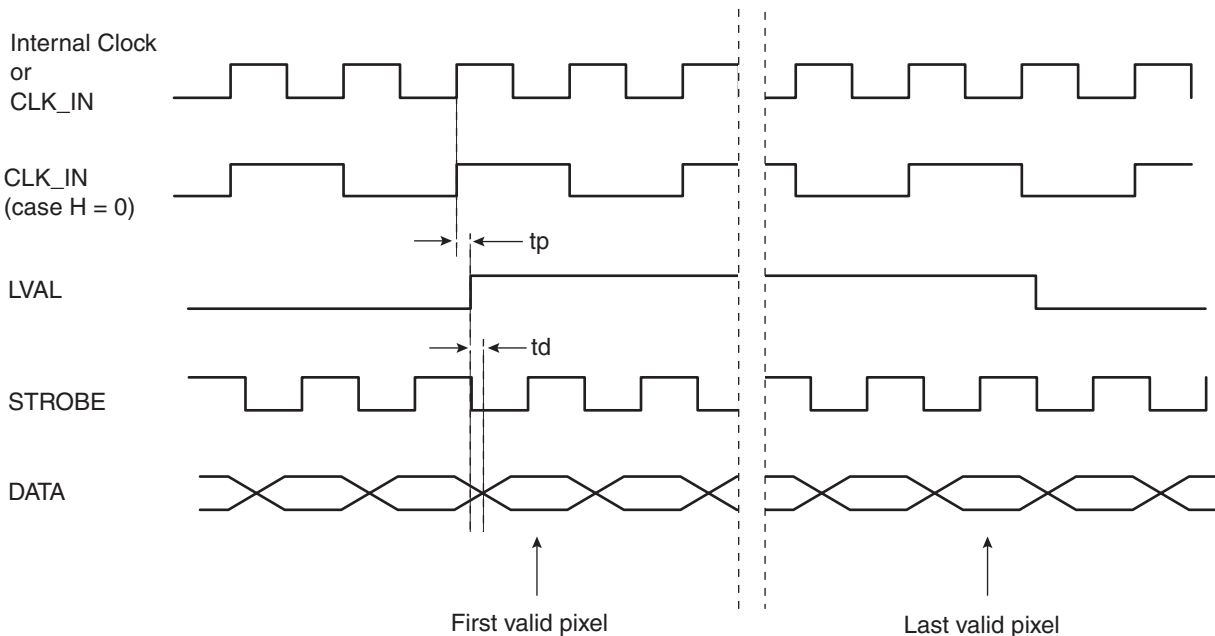

Note: The data rate frequency must be in the range of 5 to 60 MHz. Outside this range, the performances may be degraded.

If multiple cameras are synchronized (more than one camera on one acquisition board):

- The *master* camera provides DATA, STROBE and LVAL signals to the acquisition board. The others only provide DATA.
- The external clock CLK_IN must be input on each camera to guarantee perfect data synchronization.
- The trigger input(s) (TRIG1 and/or TRIG2) must be input on each camera. We recommend synchronization of the rising edge of these signals on the CLK_IN falling edge.
- Cables must be balanced between each camera (same quality and same length) to ensure perfect camera synchronization.
- The CLK_IN frequency must be equal to the CCD register frequencies. This means that the user should use H = 0. Using H = 1 or H = 2 clock modes provides LVAL jitters on the “slave” camera.
- Only *triggered and integration time controlled* (M = 3 or M = 4) can be used. These modes ensure perfect initiation of each camera’s readout phase.

9. Electrical Interface

9.1 Power Supply

It is recommended to insert a 1A fuse between the power supply and the camera.

Table 9-1. Power Supply

Signal Name	I/O	Type	Description
PWR	P	–	DC power input: +12V to +24V (±0.5V)
GND	P	–	Electrical and Mechanical ground

I = Input, O = Output, I/O = Bi-directional signal, P = Power/ground, NC = Not connected

9.2 Camera Control

The camera interface provides three LVDS signals dedicated to camera control

Table 9-2. Camera Control

Signal Name	I/O	Type	Description
TRIG1	I	RS644	Synchronization input (refer to “Synchronization Mode” on page 7)
TRIG2	I	RS644	Start Integration period in dual synchro mode (refer to “Synchronization Mode” on page 7)
CLK_IN	I	RS644	External clock for (multi-) camera synchronization (refer to “Synchronization Mode” on page 7)

I = Input, O = Output, I/O = Bi-directional signal, P = Power/ground, NC = Not connected

9.3 Video Data

Table 9-3. Video Data

Signal Name	I/O	Type	Description
ODD[11-0]	O	RS644	Odd pixel data (refer to “Output Data Timing” on page 8), ODD-00 = LSB, ODD-11 = MSB
EVEN[11-0]	O	RS644	Even pixel data (refer to “Output Data Timing” on page 8), EVEN-00 = LSB, EVEN-11 = MSB
STROBE	O	RS644	Output data clock (refer to “Output Data Timing” on page 8), data valid on the rising edge
LVAL	O	RS644	Line valid (refer to “Output Data Timing” on page 8), active high signal

I = Input, O = Output, I/O = Bi-directional signal, P = Power/ground, NC = Not connected

Note: For a single output, the multiplexed data is output in place of the odd data.

9.4 Serial Communication

The RS-232 interface enables you to define the camera’s parameters.

The RS-232 configuration is:

- Full duplex/without handshaking, the camera is configured in DCE/Modem
- 9600 bauds, 8-bit data, no parity bit, 1 stop bit

Table 9-4. Serial Communication

Signal Name	I/O	Type	Description
TX	O	RS-232	Transmitted data
RX	I	RS-232	Received data

9.4.1 Command Syntax

The valid syntax is $S=n(CR)$ with:

- S: command identification as per “Camera Command and Control” on page 5.
- n: setting value
- (CR): stands for “carriage return”

No space, nor tab may be inserted between S, =, n and (CR).

Example of a valid command:

- G=3(CR): sets the camera to gain 3 (refer to “Camera Command and Control” on page 5 for exact value calculation)

Example of non valid commands:

- G = 3(CR): spaces
- g=3(CR): g instead of G
- G=1040(CR): 1040 is outside of range

It is recommended to wait for the >OK camera return before sending a new command.

9.4.2 Command Processing

All commands received by the camera are processed:

- If the command is valid:
 - and if it is a write command, the setting is done
 - and if it is a read command, the camera returns the data separated by (CR)
 - the camera returns: >OK(CR)
- If the command is not valid:
 - nothing happens
 - the camera returns: >1 = out of range; >2 = syntax error; >4 = invalid command; others = internal error

Example: when receiving $! = 3(CR)$ the camera returns its current settings:

- A=0(CR); B=0(CR);; >OK(CR)

9.5 Storage of the Settings in EEPROM

The current settings must be saved in EEPROM before the camera is switched off. The maximum number of write cycles allowed for EEPROM is 100 000.

10. Connector Description

All connectors are on the rear panel.

Note: Cables for digital signals must be shielded twisted pairs.

10.1 Power Supply

Camera connector type: Hirose HR10A-7R-6PB (male).

Cable connector type: Hirose HR10A-7P-6S (female).

Table 10-1. Power Supply Connector Pinout

Signal	Pin	Signal	Pin
PWR	1	GND	4
PWR	2	GND	5
PWR	3	GND	6

Figure 10-1. Receptacle Viewed from Rear Face of Camera

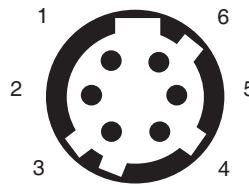

10.2 RS-232 Connector

The camera connector type is a D-Sub 9-pin female.

RTS (pin 4) and CTS (pin 6) are connected together inside the camera.

DTR (pin 7) and DSR (pin 8) are also connected together inside the camera.

Table 10-2. RS-232 Connector Pinout

Signal	Pin	Signal	Pin	Signal	Pin
NC	1	RTS	4	DTR	7
TX	2	GND	5	DSR	8
RX	3	CTS	6	NC	9

10.3 44-Pin Data and Synchro Connector

Camera connector type: D-Sub HD 44-pin female.

Note: **Unused pins must be kept open.**

When used in single (multiplexed) output, the multiplexed data is output in place of ODD data.

Table 10-3. 44-pin Data and Synchro Connector when Used in 12-bit Output Format (S = 0)

Pin	Signal	Pin	Signal	Pin	Signal	Pin	Signal
1	GND	12	–	23	ODD-03+	34	ODD-06-
2	CLK_IN+	13	–	24	ODD-08+	35	ODD-07+
3	ODD-04-	14	LVAL+	25	ODD-10-	36	ODD-01+
4	ODD-05-	15	STROBE+	26	ODD-11-	37	ODD-02+
5	ODD-07-	16	CLK_IN-	27	–	38	ODD-03-
6	ODD-00+	17	TRIG1+	28	–	39	ODD-09+
7	ODD-02-	18	TRIG1-	29	LVAL-	40	ODD-10+
8	ODD-08-	19	ODD-05+	30	STROBE-	41	–
9	ODD-09-	20	ODD-06+	31	TRIG2-	42	–
10	ODD-11+	21	ODD-00-	32	TRIG2+	43	–
11	–	22	ODD-01-	33	ODD-04+	44	GND

Table 10-4. 44-pin Data and Synchro Connector when Used in 10-bit Output Format (S = 1)

Pin	Signal	Pin	Signal	Pin	Signal	Pin	Signal
1	GND	12	–	23	ODD-03+	34	ODD-06-
2	CLK_IN+	13	–	24	ODD-08+	35	ODD-07+
3	ODD-04-	14	LVAL+	25	–	36	ODD-01+
4	ODD-05-	15	STROBE+	26	–	37	ODD-02+
5	ODD-07-	16	CLK_IN-	27	–	38	ODD-03-
6	ODD-00+	17	TRIG1+	28	–	39	ODD-09+
7	ODD-02-	18	TRIG1-	29	LVAL-	40	–
8	ODD-08-	19	ODD-05+	30	STROBE-	41	–
9	ODD-09-	20	ODD-06+	31	TRIG2-	42	–
10	–	21	ODD-00-	32	TRIG2+	43	–
11	–	22	ODD-01-	33	ODD-04+	44	GND

Table 10-5. 44-pin Data and Synchro Connector when Used in 8-bit Output Format(S = 2)

Pin	Signal	Pin	Signal	Pin	Signal	Pin	Signal
1	GND	12	–	23	ODD-03+	34	ODD-06-
2	CLK_IN+	13	–	24	–	35	ODD-07+
3	ODD-04-	14	LVAL+	25	–	36	ODD-01+
4	ODD-05-	15	STROBE+	26	–	37	ODD-02+
5	ODD-07-	16	CLK_IN-	27	–	38	ODD-03-
6	ODD-00+	17	TRIG1+	28	–	39	–
7	ODD-02-	18	TRIG1-	29	LVAL-	40	–
8	–	19	ODD-05+	30	STROBE-	41	–
9	–	20	ODD-06+	31	TRIG2-	42	–
10	–	21	ODD-00-	32	TRIG2+	43	–
11	–	22	ODD-01-	33	ODD-04+	44	GND

Table 10-6. 44-pin Data and Synchro Connector when Used in Special 2 × 8-bit Output on a Single Connector (Y = 1)

Pin	Signal	Pin	Signal	Pin	Signal	Pin	Signal
1	GND	12	EVEN-06-	23	ODD-03+	34	ODD-06-
2	CLK_IN+	13	EVEN-07-	24	EVEN-00+	35	ODD-07+
3	ODD-04-	14	LVAL+	25	EVEN-02-	36	ODD-01+
4	ODD-05-	15	STROBE+	26	EVEN-03-	37	ODD-02+
5	ODD-07-	16	CLK_IN-	27	EVEN-05+	38	ODD-03-
6	ODD-00+	17	TRIG1+	28	EVEN-06+	39	EVEN-01+
7	ODD-02-	18	TRIG1-	29	LVAL-	40	EVEN-02+
8	EVEN-00-	19	ODD-05+	30	STROBE-	41	EVEN-04-
9	EVEN-01-	20	ODD-06+	31	TRIG2-	42	EVEN-05-
10	EVEN-03+	21	ODD-00-	32	TRIG2+	43	EVEN-07+
11	EVEN-04+	22	ODD-01-	33	ODD-04+	44	GND

10.4 26-pin Data Connector

Camera connector type: D-Sub HD 26-pin female.

When in single (multiplexed) or special 2 × 8-bit mode, the outputs on this connector are all set to low.

Table 10-7. 26-pin Data Connector when Used in 12-bit Output Format (S = 0)

Pin	Signal	Pin	Signal	Pin	Signal	Pin	Signal
1	GND	8	EVEN-10+	15	EVEN-07+	22	EVEN-05+
2	EVEN-01-	9	EVEN-11-	16	EVEN-08+	23	EVEN-06+
3	EVEN-03+	10	EVEN-00-	17	EVEN-10-	24	EVEN-08-
4	EVEN-04+	11	EVEN-01+	18	EVEN-11+	25	EVEN-09-
5	EVEN-06-	12	EVEN-02+	19	EVEN-00+	26	GND
6	EVEN-07-	13	EVEN-04-	20	EVEN-02-		
7	EVEN-09+	14	EVEN-05-	21	EVEN-03-		

Table 10-8. 26-pin Data Connector when Used in 10-bit Output Format (S = 1)

Pin	Signal	Pin	Signal	Pin	Signal	Pin	Signal
1	GND	8	–	15	EVEN-07+	22	EVEN-05+
2	EVEN-01-	9	–	16	EVEN-08+	23	EVEN-06+
3	EVEN-03+	10	EVEN-00-	17	–	24	EVEN-08-
4	EVEN-04+	11	EVEN-01+	18	–	25	EVEN-09-
5	EVEN-06-	12	EVEN-02+	19	EVEN-00+	26	GND
6	EVEN-07-	13	EVEN-04-	20	EVEN-02-		
7	EVEN-09+	14	EVEN-05-	21	EVEN-03-		

Table 10-9. 26-pin Data Connector when Used in 8-bit Output Format (S = 2)

Pin	Signal	Pin	Signal	Pin	Signal	Pin	Signal
1	GND	8	–	15	EVEN-07+	22	EVEN-05+
2	EVEN-01-	9	–	16	–	23	EVEN-06+
3	EVEN-03+	10	EVEN-00-	17	–	24	–
4	EVEN-04+	11	EVEN-01+	18	–	25	–
5	EVEN-06-	12	EVEN-02+	19	EVEN-00+	26	GND
6	EVEN-07-	13	EVEN-04-	20	EVEN-02-		
7	–	14	EVEN-05-	21	EVEN-03-		

11. Mechanical Characteristics

11.1 Weight

The camera's typical weight (without lens nor lens adapter) is 220g or 7.7 ounces.

11.2 Dimensions

The camera's dimensions (without lens) are:

- 56 mm width
- 60 mm height
- 39.4 mm length

Figure 11-1. Mechanical Box Drawing and Dimensions

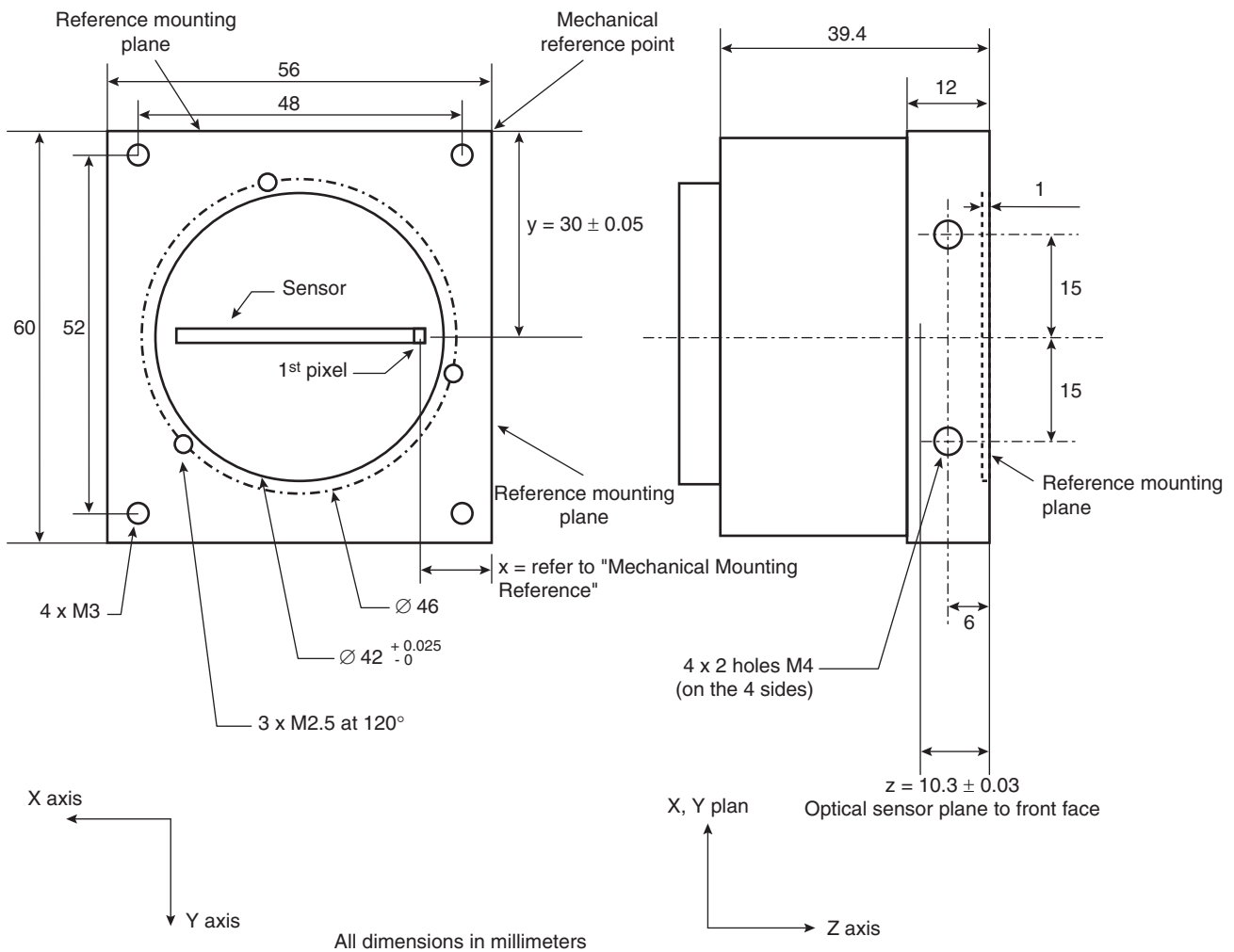

11.3 Mechanical Mounting Reference

The front panel's mechanical part is designed to support mounting of the camera. Three surfaces on this mechanical area are considered as mounting reference surfaces. This implies that the distance between these surfaces and the first active pixel is very precise (better than $\pm 50 \mu\text{m}$).

Table 11-1. Mechanical Mounting Reference

Number of Pixels	512	1024	2048	4096
x with 14 μm sensor (mm)	24.416	20.832	13.664	–
x with 10 μm sensor (mm)	–	22.880	17.760	7.520

11.4 Sensor Alignment

Figure 11-2. Sensor Alignment Diagram

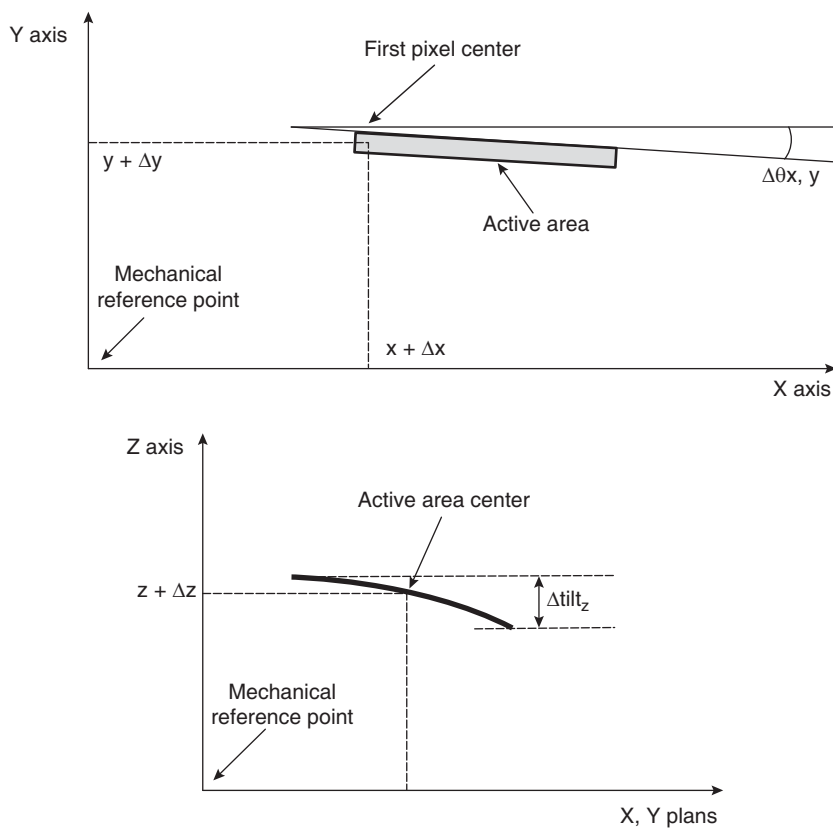

11.5 Mounting of Lens (Lens Not Supplied)

The camera can be provided with four different lens adapters, corresponding to four different options. The user must select the appropriate adapter. The following table gives recommendations according to the sensor size.

Table 11-2. Lens Mounting

Number of Pixels	512/14 μm	1024/10 μm	1024/14 μm	2048/10 μm	2048/14 μm	4096/10 μm
C mount	OK	OK	~OK ⁽¹⁾	~OK ⁽¹⁾	not usable	not usable
F mount	OK	OK	OK	OK	OK	OK
T2 (M42 x 0.75) mount	OK	OK	OK	OK	OK	OK
M42 x 1 mount	OK	OK	OK	OK	OK	OK

Note: 1. Depends on lens quality.

11.6 Heat Sink Mounting

In order to improve power dissipation, the camera can be delivered with a heat sink to be mounted by the user on the side faces of the camera. Delivery of the heat sink is an option.

12. Ordering Codes

Table 12-1. Ordering Code

Part Number	Resolution	Pixels Size	Description
AT71-SM2LV1010-BA0	1K	10 μm	AViVA M2 LV 1010
AT71-SM2LV2010-BA0	2K	10 μm	AViVA M2 LV 2010
AT71-SM2LV4010-BA0	4K	10 μm	AViVA M2 LV 4010
AT71-SM2LV0514-BA0	512	14 μm	AViVA M2 LV 0514
AT71-SM2LV1014-BA0	1K	14 μm	AViVA M2 LV 1014
AT71-SM2LV2014-BA0	2K	14 μm	AViVA M2 LV 2014
AT71KFPVIVA-ABA	–	–	F mount (NIKON)
AT71KFPVIVA-AKA	–	–	T2 mount (M42 x 0.75)
AT71KFPVIVA-ADA	–	–	M42 x 1 mount
AT71KFPVIVA-ACA	–	–	C mount
AT71KAVIVAP2C0D4A0	–	–	Cable kit: 10-meter power supply and 5-meter LVDS cables



How to reach us

Home page: www.e2v.com

Sales Office:

United Kingdom

e2v
106 Waterhouse Lane
Chelmsford
Essex CM1 2QU
Tel: +44 (0)1245 493 493
Fax: +44 (0)1245 492 492

USA

e2v
4 Westchester Plaza
Elmsford
NY 10523-1482
Tel: +1 914 592 6050
Fax: +1 914 592 5148

France

e2v
16 Burospace
F-91 572 Bievres Cedex
Tel: +33 (0) 1 6019 5500
Fax: +33 (0) 1 6019 5529

Product Contact:

e2v
Avenue de Rochepleine
BP 123 - 38521 Saint-Egrève Cedex
France
Tel: +33 (0)4 76 58 30 00

Hotline:

hotline-cam@e2v.com



Whilst e2v has taken care to ensure the accuracy of the information contained herein it accepts no responsibility for the consequences of any use thereof and also reserves the right to change the specification of goods without notice. e2v accepts no liability beyond that set out in its standard conditions of sale in respect of infringement of third party patents arising from the use of tubes or other devices in accordance with information contained herein.