

Datasheet- *Preliminary Specification*

1. Main Features

- High Sensitivity and High Dynamic Range Linear CCD
- 1024, 2048 or 4096 Resolution with 10 μm Square Pixels
- 512, 1024 or 2048 Resolution with 14 μm Square Pixels
- 100 % Aperture, Built-in Anti Blooming, No Lag
- GigE Vision Interface Standard and GenICam Compliant Interface
- High Data Rate up to 62 Mpixels/s
- Flexible and Easy to Operate Via GigE Vision with a User Friendly GUI (Graphical User Interface) to Control the Following Functions:
 - Gain Range: 39 dB by Step of 0.035 dB
 - Bit Depth: 8, 10 or 12-bit Data
 - Dynamic Range: 67 dB
 - Offset (for Contrast Expansion)
 - Synchronization Modes: Timed, Trigger Width or Trigger Controlled Modes
- Flat Field Correction (Lens and Light Non-uniformity Correction)
- Automatic Taps Balancing
- Single Power Supply: DC 12V to 24V
- Very Compact Design: 56 \times 60 \times 39.4 mm (w,h,l)
- High Reliability, RoHS, CE and FCC Compliant
- C or F (Nikon) Mount Adapter (Lens Not Supplied)



2. Product Description

This new family of Gigabit Ethernet UM2 cameras is designed with our three concepts accuracy, versatility and easy implementation with the same compact housing design: 56 \times 60 \times 39.4 mm of the AViiVA SM2 family.

- The same compact mechanical design incorporates all the sensors, from 512 to 4096 pixels.
- This camera is able to work up to 12 bit, with dedicated electronics offering an excellent dynamic range.
- This UM2 GE is fully programmable, offering different integration time, gain and offset. Two external triggers allow to synchronize several cameras.
- For OEMs migrating from AViiVA SM2 to AViiVA UM2, the camera does not require a new optic design because the pixel size remains unchanged: 10 μm or 14 μm . Also with GigE vision interface and GenICam compliant interface, you no longer need a frame grabber which means significant system cost savings.

Visit our website: www.e2v.com
for the latest version of the datasheet

3. Applications

Being a standard interface dedicated to machine vision industry, GigE Vision will gain rapid acceptance in the market place. High data rate, standard interface hardware, throughputs of 94 Mbyte/second (with cable length up to 100 meters and more with network equipment), camera control, are all additional criteria for this new attractive interface option. Performance and reliability of this GigE camera make it well suited for the most demanding industrial applications, from web inspection to document scanning, from surface inspection to metrology.

4. Typical Performances

Test conditions:

- Maximum data rate (2×31 MHz)
- High source 3200K with BG38 filter 2 mm thickness
- LSB are given for 8-bit depth configuration

Table 4-1. Typical Performances

| Sensor Characteristics at Maximum Pixel Rate | | | | | |
|--|--------------------------|---|-----------|---|------|
| Resolution | Pixels | 512 | 1024 | 2048 | 4096 |
| Pixel size (square) | μm | 14 | 14 | 14 | — |
| | μm | — | 10 | 10 | 10 |
| Maximum line rate | kHz | 109 | 57 | 29 | 15 |
| Anti blooming | | × 100 | | | |
| Radiometric Performances at Maximum Pixel Rate and T_{amb} = 25°C | | | | | |
| Bit depth | Bits | 12 (also configurable in 0 bit or 10 bit) | | | |
| Spectral range | nm | 250 to 1100 | | | |
| Linearity | % | < 1% | | | |
| Gain range | (step of 0.035 dB) dB | Gmin -18 | Gnom 0 | Gmax 21 | |
| Peak response | (typical) | | | | |
| 14 μm pitch | LSB/nJ/cm ² | 130 | 1040 | 4180 | |
| 10 μm pitch | LSB/nJ/cm ² | 50 | 400 | 1600 | |
| Output RMS noise | (typical) | | | | |
| Dynamic range | dB | 67.4 | 49 | 37 | |
| Effective bits | Bits | 11.2 | 8.2 | 6.2 | |
| Input RMS Noise | (typical) | | | | |
| 14 μm pitch | pJ/cm ² | 14 | | | |
| 10 μm pitch | pJ/cm ² | 37 | | | |
| Mechanical and Electrical Interface | | | | | |
| Size (w × h × l) | mm | 56 × 60 × 39.4 | | | |
| Lens mount | | C,F | | | |
| Sensor alignment (refer to Section 13.4) | | $\Delta x,y = \pm 50 \mu\text{m}$ $\Delta\theta_{x,y} = \pm 0.2^\circ$ | | $\Delta z = \pm 30 \mu\text{m}$ $\Delta\text{tilt}_z = \pm 0.35 \mu\text{m}$ | |
| Power supply | V | DC, single 12 to 24 V | | | |
| Power dissipation | W | < 9 | | | |
| Operating temperature | °C | 0 to 45 (non-condensing) | | | |

Table 4-1. Typical Performances

| | | |
|--------------------------|----|-----------|
| Storage temperature | °C | -40 to 75 |
| Spectral Response | | |
| | | |

5. Camera Description

Figure 5-1. Camera Synoptic

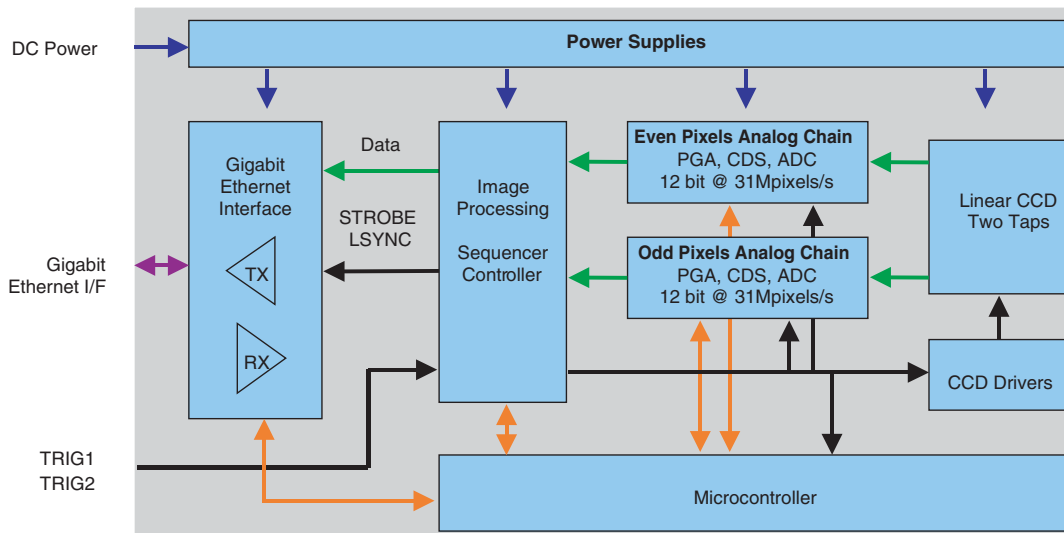

Note: PGA stands for Programmable Gain Array.

The camera is based on a two-tap linear CCD. Therefore, two analog chains process odd and even pixel outputs of the linear sensor. The CCD signal processing encompasses the correlated double sampling (CDS), the dark level correction (dark pixel clamping), the gain (PGA) and offset correction and finally the analog to digital conversion on 12 bit. Digital data are then processed into an FPGA (Flat Field Correction, contrast expansion, automatic taps balancing and test pattern generation).

- The camera is powered by a single DC power supply from 12V to 24V.
- The functional interface (data and control) is provided with the GigE Vision interface.
- The data is provided on two channels. The data format can be configured in 8, 10 or 12 bit.
- The camera can be used with external triggers (TRIG1 and TRIG2 signals) in different trigger modes (refer to [Section 8.1](#)).

- The camera configuration and settings are performed via the GigE Vision interface. This interface is used for:
 - Gain, offset setting
 - Dynamic range, data rate setting
 - Trigger mode setting: free run or external trigger modes
 - Integration time setting: in free running and external trigger mode
 - Flat-field correction

6. Standard Conformity

The cameras have been tested in the following conditions:

- Shielded power supply cable
- Shielded and twisted pairs data transfer cable
- Linear AC-DC power supply

e2v recommends using the same configuration to ensure the compliance with the following standards.

6.1 RoHS Conformity

AViiVA cameras comply with the requirements of the RoHS directive

6.2 CE Conformity

AViiVA UM2 cameras comply with the requirements of the European EMC directive 89/336/CEE (EN50081-2, EN61000-6-2)

6.3 FCC Conformity

AViiVA UM2 cameras comply with Part 15 of FCC rules. Operation is subject to the following two conditions:

- This device may not cause harmful interference, and
- This device must accept any interference received, including interference that may cause undesired operation.

This equipment has been tested and found to comply with the limits for a Class A digital device, pursuant to part 15 of the FCC Rules. These limits are designed to provide reasonable protection against harmful interference when the equipment is operated in a commercial environment. This equipment generates, uses, and can radiate radio frequency energy and, if not installed and used in accordance with the instruction manual, may cause harmful interference to radio communications. Operation of this equipment in a residential area is likely to cause harmful interference in which case the user will be required to correct the interference at his own expense.

Warning: Changes or modifications to this unit not expressly approved by the party responsible for compliance could void the user's authority to operate this equipment.

6.4 GigE Vision Compliance

AViiVA UM2 cameras comply with the GigE Vision V1 standard.

7. Camera Features

7.1 Flat Field Correction

The Flat Field Correction consists in applying $(X - B) \times A$ formula to each pixel value. This allows to correct:

- The CCD sensor Dark Signal Non-Uniformity (DSNU) when necessary
- The Lens vignetting
- The light source non-uniformity

7.1.1 Calibration Procedure:

1. Set the camera in the useful configuration
2. Put the camera in dark and start the FPN calibration, the camera calculates the B coefficient for each pixel
3. Switch on the light and place a white reference in front of the camera. Be careful, the quality of this reference is important to get a good calibration
4. Set parameters (light level, integration time, gain) to get an output level between half and full dynamic range for better results
5. Enable or Disable the FFC filter depending on the reference quality. This filter, when enabled before starting calibration, will mask the reference small defects.
6. Start Flat Field calibration

After processing calibration of the camera the user must enable the calculated FFC

7.2 Pixel Format

The pixel format is programmable:

- Two taps 8 bit
- Two taps 10 bit
- Two taps 12 bit

The pixel frequency is programmable:

31.25 MHz or 15.625 MHz

7.3 Test Pattern

In normal mode, the digital video signal from the sensor is available at the output interface.

For test purpose a digital pattern is generated and can be available instead of video signal at the output interface. The pattern is fixed.

The digital pattern is ramp up from 0 LSB code to 4095 LSB code (line width); same pattern for each line:

Figure 7-1. Test Pattern



Note: This is useful to validate the connection to the acquisition system before adjustment operations relative to image capture.

7.4 Integration Time and Line Period

These parameters are used in synchronization modes. Both values are programmable within the range of one to 6553 μ s.

7.5 LED Indicator

The red-green LED on the rear panel gives information on internal state of the camera. On power up, after internal configuration, the LED flashes on and has the following behavior (decreasing priority order):

- Normal situation: continuous green
- Waiting for external trigger (triggered and ITC modes): slow blinking green
- External trigger frequency too high: slow blinking red and green
- Internal hardware error or configuration error: continuous red

8. Timing

8.1 Synchronization Modes

Three different modes may be defined under user control.

The LINE1 and LINE2 signals may be used to trigger external events and to control the integration time.

8.2 Timed Modes

The integration time is set by programming the ExposureTimeAbs feature. The integration and readout periods start automatically and immediately after the rising edge of the trigger source. The trigger source could be either the end of Timer1 or the LINE1 signal.

8.3 Free Run Mode

If the Timer1 is selected as the trigger source, the integration and readout periods start automatically after the previous period. The line acquisition is periodic. The readout time depends on the pixel number and the pixel rate.

Table 8-1. Free Run Mode Timing Values

| Label | Description | Min | Typ | Max |
|-------|---|-----|-----------|-------|
| ti | Integration time duration | | | 13 ms |
| tg | Consecutive integration period gap (at maximum frequency) | | 6 μ s | |
| tt | Integration period stop to read-out start delay | | 1 μ s | |

Figure 8-1. Integration Time

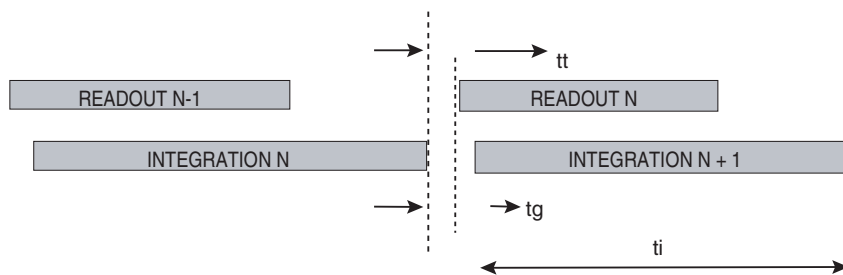

8.3.0.1 External Trigger With Exposure Time Variable

If the LINE1 is selected as the trigger source, the integration period starts automatically after the rising edge of LINE1 signal. This integration period is immediately followed by a readout period. The readout time depends on pixel number and the pixel rate. The TriggerSource feature must be set to LINE1.

Triggered Mode Timing Values

| Label | Description | Min | Typ | Max |
|-------|---|-----------|-------------|-------|
| ti | Integration time duration | 5 μ s | | 13 ms |
| td | LINE1 rising to integration period start delay | | 5.5 μ s | |
| tt | Integration period stop to read-out start delay | | 1 μ s | |
| ts | Integration period stop to LINE1 rising set-up time | 4 μ s | | |
| th | LINE1 hold time (pulse high duration) | 5 μ s | | |

Figure 8-2. Integration Time

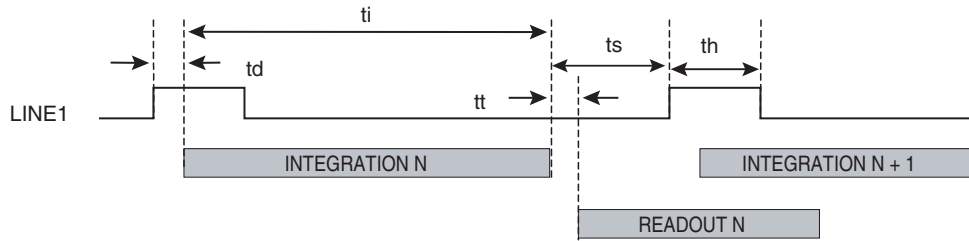

8.3.1 Trigger Width Modes

The width of the current line trigger signal pulse is used to control the exposure duration. The integration period starts immediately after the falling edge of LINE1 signal. The integration period stops immediately after the rising edge of LINE1 signal. This integration period is immediately followed by a readout period. The readout time depends on pixel number and the pixel rate. The TriggerSource feature must be set to LINE1

Table 8-2. Triggered Mode Timing Values

| Label | Description | Min | Typ | Max |
|-------|---|-----------|-------------|-----|
| ti | Integration time duration | 5 μ s | | |
| td1 | LINE1 falling to integration period start delay | | 100 ns | |
| td2 | LINE1 rising to integration period stop delay | | 1.3 μ s | |
| tt | Integration period stop to read-out start delay | | 1 μ s | |
| th | LINE1 hold time (pulse high duration) | 5 μ s | | |

Figure 8-3. Integration Time

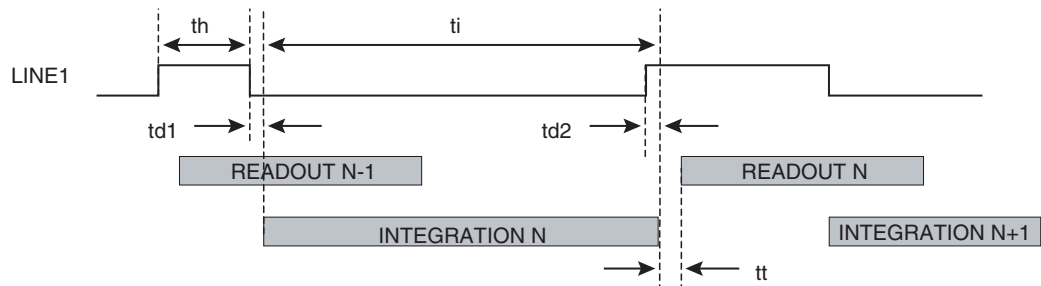

8.3.2 Trigger Controlled Modes

One or two line trigger signals are used to control the exposure duration.

8.3.2.1 External Trigger With Maximum Exposure Time

The integration and the readout periods start immediately after the rising edge of LINE1 signal. The readout time depends on pixel number and the pixel rate. The TriggerSource feature must be set to LINE1

Table 8-3. Triggered Mode Timing Values

| Label | Description | Min | Typ | Max |
|-------|---|-----------|-----------|-----|
| ti | Integration time duration | 5 μ s | | |
| td1 | LINE1 rising to integration period start delay | | 100 ns | |
| tt | Integration period stop to read-out start delay | | 1 μ s | |
| th | LINE1 hold time (pulse high duration) | 5 μ s | | |

Figure 8-4. Integration Time

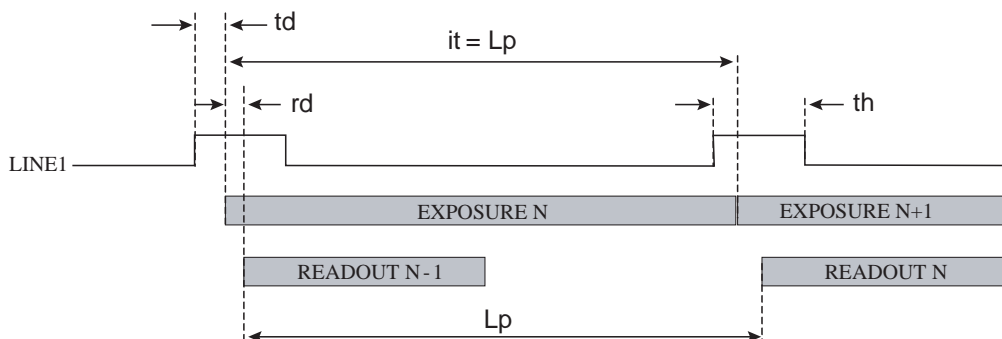

8.3.2.2 Two External Trigger With External Exposure Time

The integration period starts immediately after the rising edge of LINE2 signal. The integration period stops immediately after the rising edge of LINE1 signal. This integration period is immediately followed by a readout period. The readout time depends on pixel number and the pixel rate. The ExposureStartTriggerSource feature must be set to LINE2. The ExposureEndTriggerSource feature must be set to LINE1

Table 8-4. Triggered Mode Timing Values

| Label | Description | Min | Typ | Max |
|-------|---|-----------|-------------|-----|
| ti | Integration time duration | 5 μ s | | |
| td1 | LINE2 rising to integration period start delay | | 100 ns | |
| td2 | LINE1 rising to integration period stop delay | | 1.3 μ s | |
| tt | Integration period stop to read-out start delay | | 1 μ s | |
| th | LINE1 hold time (pulse high duration) | 5 μ s | | |

Figure 8-5. Integration Time

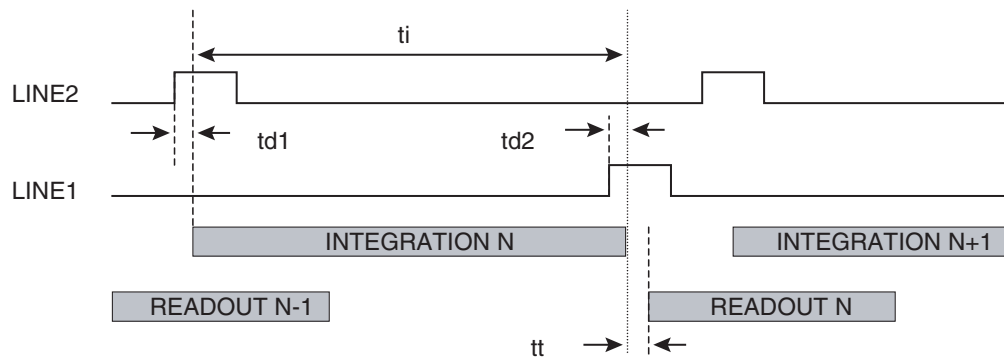

9. Camera Command and Control

Camera configuration is set through GigE Vision interface according to the GVCP protocol and the GenI-Cam standard.

Table 9-1. Camera Command and Control

| Setting | Access | Description | Value |
|-------------------------------|--------|---|--------|
| Width | RO | Image width in pixel | Width |
| Height | RW | Image height in pixel | Height |
| PixelFormat | RW | 2 taps 8 bit Mono8 | |
| | RW | 2 taps 10 bit Packed10 | |
| | RW | 2 taps 12 bit Packed12 | |
| | RW | 2 taps 12 bit Mono16 | |
| PayloadSize | RO | Image payload size in byte | |
| AcquisitionMode | RW | Continuous | |
| AcquisitionStart | RW | Start the acquisition depending on AcquisitionMode | |
| AcquisitionStop | RW | Stop the acquisition | |
| CCD register frequency | RW | Clock pixel 31.25 MHz | 0 |
| | RW | Clock pixel 15.625 MHz | 1 |
| Integration time | RW | 1 to 4095 (in μ s) | xx |
| Line period | RW | 1 to 4095 (in μ s) | xx |
| Gain | RW | Gain (Analog All) -15 to 18 dB (step 3 dB) | xx |
| | | Gain (All) -3 to 3 dB (step 0.0351dB) | |
| Offset | RW | Offset global = -4096 to 4095 (in LSB 12 bit) | xx |
| Gain adjust | RW | Gains adjustment (Usertap1&2) $\pm 0.13\text{dB} = \pm 1.56\%$ (128 steps) | xx |
| Offset adjust | RW | Offsets adjustment (two channels) xx = -128 to 127 (± 16 LSB, step of 1/8 LSB 12 bit) | xx |
| Synchronization mode | RW | Timed mode. Integration time period programmable | |
| | RW | Trigger width mode. The width of the current line trigger signal pulse is used to control the exposure duration | |
| | RW | Trigger controlled mode. Synchronization of the line period (start and duration) with integration time controlled by one or two signals | |
| Signal source | RW | CCD sensor | |
| | | CCD sensor + FFC correction | |
| | | Test pattern 1 and test pattern 2 | |
| FPN calibration (FFC user) | RW | Calibration stop in darkness | 0 |
| | | Calibration start in darkness | 1 |

Table 9-1. Camera Command and Control (Continued)

| Setting | Access | Description | Value |
|---|--------|--|---------|
| PRNU calibration (FFC user) | RW | Calibration stop under illumination | 0 |
| | | Calibration start under illumination | 1 |
| Reset PRNU | WO | Reset FFC gain coefficient | 0 |
| Reset FPN | WO | Reset FFC offset coefficient | 0 |
| PRNU | RW | FFC gain coefficient | 16 bit |
| FPN | RW | FFC offset coefficient | 16 bit |
| FFC save | WO | Save calibration number 1 | 1 |
| | | Save calibration number 2 | 2 |
| | | Save calibration number 3 | 3 |
| FFC Restore | RW | Save calibration number 4 | 4 |
| | | Restore factory calibration | 0 |
| | | Restore calibration number 1 | 1 |
| | | Restore calibration number 2 | 2 |
| | | Restore calibration number 3 | 3 |
| FFC Filter (FFC user) (advanced mode) | RW | Median filter disabled | 0 |
| | | Median filter enabled (3) | 1 |
| | | Median filter enabled (5) | 2 |
| | | Median filter enabled (7) | 3 |
| Blank Tap Balance | RW | Tap balance stop in darkness | 0 |
| | | Tap balance start in darkness | 1 |
| White tap balance | RW | Tap balance stop under illumination | 0 |
| | | Tap balance start under illumination | 1 |
| Tap balance configuration save (Backup) | | Tap balance configuration (gain/offset) in bank 1 | 1 |
| | | Bank 2 | 2 |
| | | Bank 3 | 3 |
| | | Bank 4 | 4 |
| Tap balance configuration restore | | Restore tap balance configuration (gain/offset) from factory bank | 0 |
| | | Restore tap balance configuration (gain/offset) from bank 1 | 1 |
| | | Bank 2 | 2 |
| | | Bank 3 | 3 |
| | | Bank 4 | 4 |
| ID camera | RO | ID client, xx = 0 to 32 characters max | "AT7.." |

Table 9-1. Camera Command and Control (Continued)

| Setting | Access | Description | Value |
|------------------------------|--------|---------------------------------------|--------------------|
| Model Name | RO | Model description | AviivaUM 2GE-v1 |
| ID Client | RW* | ID client | 02/07"..." |
| Camera status | RO | Camera state | 32 bit |
| Camera version | RO | µC version/FPGA version / ... | |
| Camera configuration save | WO | Save configuration client number 1 | 1 |
| | | Save configuration client number 2 | 2 |
| | | Save configuration client number 3 | 3 |
| | | Save configuration client number 4 | 4 |
| Camera configuration restore | RW | Restore factory configuration | 0 |
| | | Restore configuration client number 1 | 1 |
| | | Restore configuration client number 2 | 2 |
| | | Restore configuration client number 3 | 3 |
| | | Restore configuration client number 4 | 4 |
| | | Restore configuration advanced user | 5 |

10. Upgrade

This camera is fully upgradable using the GigE interface. This prevents from returning the camera and ensures fast correction and easy improvement.

11. Electrical Interface

11.0.1 Power Supply

It is recommended to insert a 2A fuse between the power supply and the camera.

Table 11-1. Power Supply

| Signal name | I/O | Type | Description |
|-------------|-----|------|---------------------------------------|
| PWR | P | – | DC power input : +12V to +24V (±0.5V) |
| GND | P | – | Electrical and Mechanical ground |

Note: I = input, O = output, I/O = bi-directional signal, P = power/ground, NC = not connected

11.1 Camera Control

Table 11-2. Camera Control

| Signal name | I/O | Type | Description |
|-------------|-----|-----------|---|
| LINE1/TRIG1 | I | TTL/RS644 | Synchronization input (refer to Section 8.1) |
| LINE2/TRIG2 | I | TTL/RS644 | Start Integration period in dual synchronization mode (refer to Section 8.1) |

Note: I = input, O = output, I/O = bi-directional signal, P = power/ground, NC = not connected

11.2 Gigabit Ethernet

Table 11-3. Gigabit Ethernet

| Signal name | I/O | Type | Description |
|-------------|-----|------|-------------|
| MDI_ [3-0]+ | I/O | – | |
| MDI_ [3-0]- | I/O | – | |

Note: I = input, O = output, I/O = bi-directional signal, P = power/ground, NC = not connected

12. Connector Description

All connectors are on the rear panel.

Note: Cables for digital signals shall be shielded twisted pairs.

12.1 Power Supply

Camera connector type: Hirose HR10A-7R-6PB (male) Cable connector type: Hirose HR10A-7P-6S (female)

Table 12-1. Power Supply Connector Pinout

| Pin | Signal | Pin | Signal |
|-----|--------|-----|--------|
| 1 | PWR | 4 | GND |
| 2 | PWR | 5 | GND |
| 3 | PWR | 6 | GND |

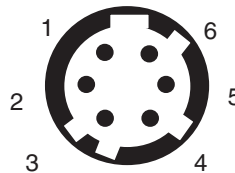

Note: Receptacle viewed from back of camera

12.2 Camera Control Connector

Camera connector type : Hirose HR10A-7R-5SB (female)

Cable connector type : Hirose HR10A-7P-5P (male)

Table 12-2. Camera Control Connector Pinout

| Signal | Pin | Signal | Pin |
|-------------|-----|--------|-----|
| LINE1/TRIG1 | 1 | GND | 4 |
| GND | 2 | NC | 5 |
| LINE2/TRIG2 | 3 | | |

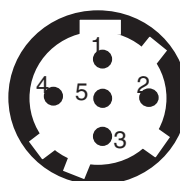

Note: Receptacle viewed from back of camera

12.3 Gigabit Ethernet Connector

Camera connector type : RJ45 9-pin female

Table 12-3. Gigabit Ethernet Connector Pinout

| Pin | Signal | Pin | Signal |
|-----|--------|-----|--------|
| 1 | MDI_0+ | 5 | MDI_2- |
| 2 | MDI_0- | 6 | MDI_1- |
| 3 | MDI_1+ | 7 | MDI_3+ |
| 4 | MDI_2+ | 8 | MDI_3- |

13. Mechanical Characteristics

13.1 Weight

The camera typical weight (without lens nor lens adapter) is 220 g (typical)

13.2 Dimensions

The camera dimension (without lens) is: W = 56 mm, H = 60 mm, L = 39.4 mm

Figure 13-1. Mechanical Characteristics

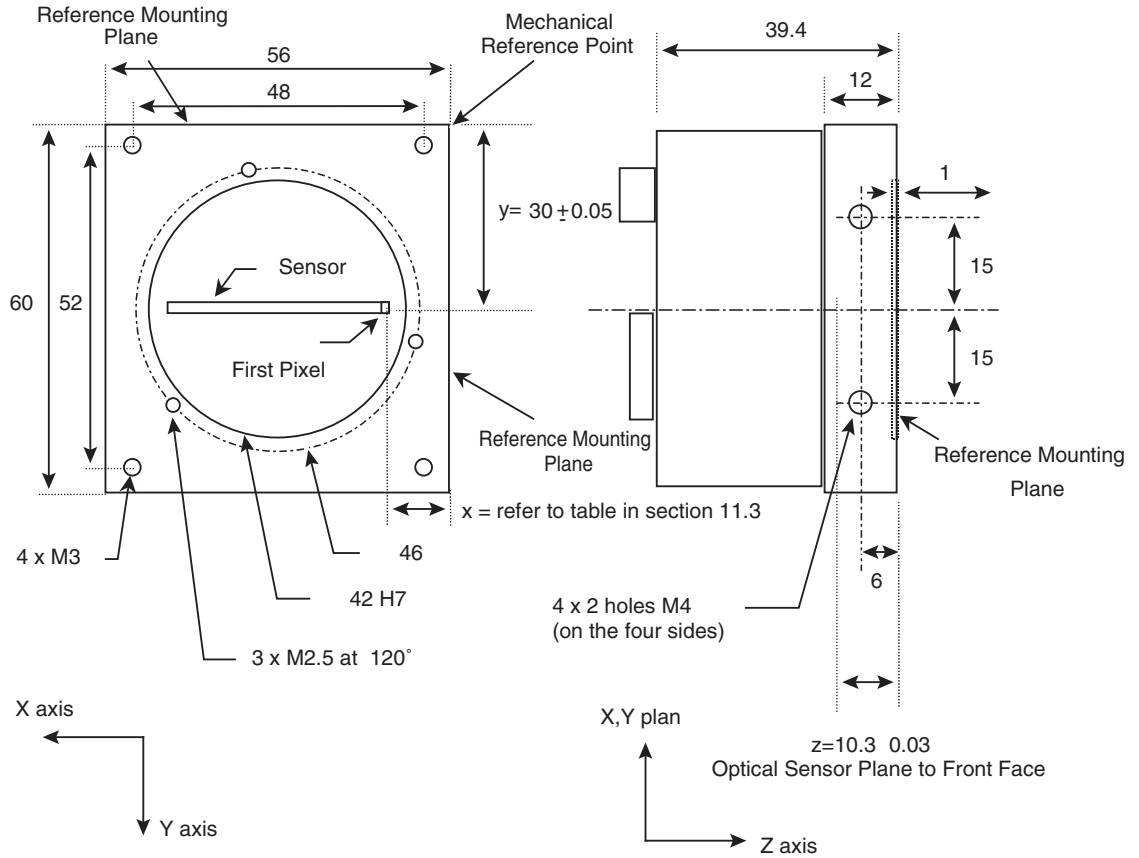

Note: All dimensions are in millimeter

13.3 Mechanical Mounting Reference

The front panel mechanical part is designed to support the mounting of the camera. On this mechanical part, three surfaces are considered as mounting reference surface; that is the distance between these surfaces and the first active pixel are known very precisely (better than $\pm 100\mu\text{m}$).

Table 13-1. Number of Pixel

| Number of pixel | 512 | 1024 | 2048 | 4096 |
|-------------------------------------|-------|-------|-------|------|
| x with 14 μm sensor (nm) | 24416 | 20832 | 13664 | |
| x with 10 μm sensor (nm) | | 22880 | 17760 | 7520 |

13.4 Sensor Alignment

Figure 13-2. Sensor Alignment Diagram

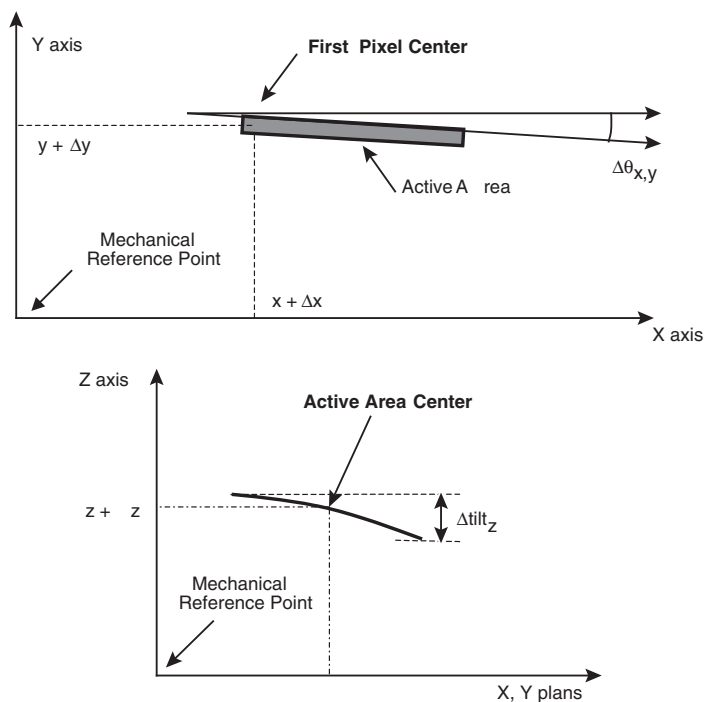

14. Lens Mounting (Lens Not Supplied)

The camera can be provided with three different lens adapters, corresponding to three different options. The customer has to select the correct adapter. The following table gives recommendations according to the sensor size

Table 14-1. Lens Mounting

| Number of pixel | 512/14µm | 024/10µm | 1024/14µm | 2048/10µm | 2048/14µm | 4096/10µm |
|-----------------|----------|----------|---------------------|---------------------|------------|------------|
| C mount | OK | OK | = OK ⁽¹⁾ | = OK ⁽¹⁾ | Not usable | Not usable |
| F mount | OK | OK | OK | OK | OK | OK |

Note: 1. Depends on the lens quality.

15. Ordering Codes

Table 15-1. Ordering Codes

| Part Number | Resolution | Pixels size | Description |
|--------------------|------------|-------------|-------------------|
| AT71YUM2GE1010-BA0 | 1 K | 10 µm | AViVA UM2 GE 1010 |
| AT71YUM2GE2010-BA0 | 2 K | 10 µm | AViVA UM2 GE 2010 |
| AT71YUM2GE4010-BA0 | 4 K | 10 µm | AViVA UM2 GE 4010 |
| AT71YUM2GE0514-BA0 | 512 | 14 µm | AViVA UM2 GE 0514 |
| AT71YUM2GE1014-BA0 | 1 K | 14 µm | AViVA UM2 GE 1014 |
| AT71YUM2GE2014-BA0 | 2 K | 14 µm | AViVA UM2 GE 2014 |
| AT71KFPVIVA-ABA | | | F mount (NIKON) |
| AT71KFPVIVA-ACA | | | C mount |



How to reach us

Home page: www.e2v.com

Sales Office:

United Kingdom

e2v
106 Waterhouse Lane
Chelmsford
Essex CM1 2QU
Tel: +44 (0)1245 493 493
Fax: +44 (0)1245 492 492

USA

e2v
4 Westchester Plaza
Elmsford
NY 10523-1482
Tel: +1 914 592 6050
Fax: +1 914 592 5148

France

e2v
16 Burospace
F-91 572 Bievres Cedex
Tel: +33 (0) 1 6019 5500
Fax: +33 (0) 1 6019 5529

Asia Pacific

e2v
Bank of China Tower
30th floor office 7
1 Garden Rd Central
Hong Kong
Tel: +852 2251 8227/8/9
Fax: +852 2251 8383

Product Contact:

e2v
Avenue de Rochepleine
BP 123 - 38521 Saint-Egrève Cedex
France
Tel: +33 (0)4 76 58 30 00
Hotline:
hotline-cam@e2v.com

Whilst e2v has taken care to ensure the accuracy of the information contained herein it accepts no responsibility for the consequences of any use thereof and also reserves the right to change the specification of goods without notice. e2v accepts no liability beyond that set out in its standard conditions of sale in respect of infringement of third party patents arising from the use of tubes or other devices in accordance with information contained herein.